

The perturbations  $\phi_{2,1}$  and  $\phi_{1,5}$   
of the minimal models  $M(p, p')$   
and the trinomial analogue of Bailey's lemma

Alexander Berkovich<sup>1</sup> and Barry M. McCoy<sup>2</sup>

*Institute for Theoretical Physics  
State University of New York  
Stony Brook, NY 11794-3840*

Paul A. Pearce<sup>3</sup>

*Department of Mathematics and Statistics  
University of Melbourne  
Parkville, Victoria 3052, Australia*

---

<sup>1</sup> alexb@insti.physics.sunysb.edu

<sup>2</sup> mccoy@max.physics.sunysb.edu

<sup>3</sup> pap@maths.mu.oz.au

## Abstract

We derive the fermionic polynomial generalizations of the characters of the integrable perturbations  $\phi_{2,1}$  and  $\phi_{1,5}$  of the general minimal  $M(p, p')$  conformal field theory by use of the recently discovered trinomial analogue of Bailey's lemma. For  $\phi_{2,1}$  perturbations results are given for all models with  $2p > p'$  and for  $\phi_{1,5}$  perturbations results for all models with  $\frac{p'}{3} < p < \frac{p'}{2}$  are obtained. For the  $\phi_{2,1}$  perturbation of the unitary case  $M(p, p+1)$  we use the incidence matrix obtained from these character polynomials to conjecture a set of TBA equations. We also find that for  $\phi_{1,5}$  with  $2 < p'/p < 5/2$  and for  $\phi_{2,1}$  satisfying  $3p < 2p'$  there are usually several different fermionic polynomials which lead to the identical bosonic polynomial. We interpret this to mean that in these cases the specification of the perturbing field is not sufficient to define the theory and that an independent statement of the choice of the proper vacuum must be made.

## 1. Introduction

The theory of perturbations of conformal field theory was initiated by Zamolodchikov [1]-[3] who introduced a sufficient condition, known as the "counting argument", for an operator to provide an integrable perturbation of the minimal conformal field theories  $M(p, p')$ . It is well known that this argument indicates that the operators  $\phi_{1,3}$ ,  $\phi_{1,2}$ ,  $\phi_{2,1}$  and  $\phi_{1,5}$  are integrable whenever they are relevant. Of these perturbations the  $\phi_{1,3}$  is the best understood and is known to be related to the affine Lie algebra  $A_1^{(1)}$ . On the one hand it is realized as the scaling limit of RSOS lattice models [4]-[5] which are restrictions of the XXZ [6] and XYZ [7]-[8] spin chains. In the field theory context it is related to restrictions of the sine-Gordon model [9]-[10]. The scattering matrices [9]-[10], Thermodynamic Bethe's Ansatz (TBA) equations [11] and the vacuum expectation values of some local operators are known [12]-[13]. In all studies there is agreement with the perturbative treatment and there is a sense in which the perturbation may be said to define the model.

The other three perturbations,  $\phi_{2,1}$ ,  $\phi_{1,2}$ , and  $\phi_{1,5}$ , are not nearly so well understood. They are known to be related to the affine Lie algebra  $A_2^{(2)}$  and to the Izergin-Korepin lattice model [14]. In the field theory context they are related to the Bullough-Dodd[15]/Zhiber-Mikhailov-Shabat[16]model. In contrast to the unique way to restrict the XXZ model there are two different restrictions for the Izergin-Korepin model. One is the restriction known as the dilute  $A_L$  model of [17]-[19] and the other is the restriction due to Kuniba [20]. In principle these restrictions can be studied for all models  $M(p, p')$  but

in practice the unitary case  $M(p, p + 1)$  has been investigated the most. In field theory the S matrices for these perturbations have been determined [21]-[24] and TBA equations have been obtained for the following cases: The  $\phi_{2,1}$  perturbation of  $M(4, 5)$  [25] and of  $M(5, 6)$  [26], the  $\phi_{2,1}$  perturbation of  $M(p, 2p - 1)$  and the  $\phi_{1,5}$  perturbation of  $M(p, 2p + 1)$  of [27]-[29], the  $\phi_{1,5}$  perturbation of  $M(3, 10)$ ,  $M(3, 14)$ ,  $M(3, 16)$  by [30] and the  $\phi_{1,2}$  perturbation of  $M(3, 4)$  [31].

One of the reasons that the results for the  $\phi_{2,1}$ ,  $\phi_{1,2}$  and  $\phi_{1,5}$  perturbations are not nearly so extensive as for  $\phi_{1,3}$  is that there appear to be new physical effects which are not present for the  $\phi_{1,3}$  perturbation. These effects are seen vividly in the recent study of vacuum expectation values by Fateev, Lukyanov, Zamolodchikov and Zamolodchikov [13]. In particular they find for the  $\phi_{1,5}$  perturbation of the minimal model  $M(p, p')$  that in the region  $2 < p'/p \leq 8/3$  the mass defined by perturbation theory is negative. This indicates that a non perturbative definition of the vacuum must be given and is often a signal that level crossing of the vacuum has occurred [32]. Similarly for the  $\phi_{2,1}$  perturbation they find a problem with vacuum definition for  $3p > 2p'$ . None of these problems has been found to occur for the  $\phi_{1,3}$  perturbation.

In this paper we study the  $\phi_{2,1}$  and the  $\phi_{1,5}$  perturbations by the method of fermionic representations of Virasoro characters and Rogers-Ramanujan identities. This approach gives results for  $\phi_{2,1}$  for all values of  $p'/p$  and for  $\phi_{1,5}$  for  $2 < p'/p < 3$  and thus gives results even in the regime where the perturbative definition of the field theory leads to problems of vacuum choice.

This method began several years after the work of [1]-[3] when it was proposed [33]-[34] that integrable perturbations are closely connected to the various different fermionic representations of the characters of the model. For example, for the minimal models the (bosonic) representation of the characters  $\chi_{r,s}^{(p,p')}(q)$  (normalized to 1 at  $q = 0$ ) is [35]

$$\chi_{r,s}^{(p,p')}(q) = \frac{1}{(q)_\infty} \sum_{j=-\infty}^{\infty} \left( q^{j(pp'j + p'r - ps)} - q^{(pj+r)(p'j+s)} \right) \quad (1.1)$$

where

$$(a)_n = \begin{cases} \prod_{j=0}^{n-1} (1 - aq^j) & \text{for } n \geq 1 \\ 1 & \text{for } n = 0. \end{cases} \quad (1.2)$$

which have central charge

$$c = 1 - \frac{6(p - p')^2}{pp'} \quad (1.3)$$

and conformal dimensions

$$\Delta_{r,s} = \frac{(ps - p'r)^2 - (p - p')^2}{4pp'} \quad (1.4)$$

where  $p$  and  $p'$  are relatively prime integers with  $p < p'$ . It was conjectured in [34] and proven in [36]-[37] that for  $M(p, p+1)$  the character  $\chi_{1,1}^{(p,p+1)}(q)$  has the fermionic representation

$$\sum_{\mathbf{m}_{p-2} \equiv 0 \pmod{2}} q^{\frac{1}{4}\mathbf{m}\mathbf{C}_{p-2}\mathbf{m}} \frac{1}{(q)_{m_1}} \prod_{j=2}^{p-2} \left[ \begin{matrix} (\frac{1}{2}\mathbf{I}_{p-2}\mathbf{m})_j \\ m_j \end{matrix} \right]_q = \chi_{1,1}^{(p,p+1)}(q) \quad (1.5)$$

where the  $p \times p$  dimensional matrices

$$(\mathbf{I}_p)_{j,k} = \delta_{j,k-1} + \delta_{j,k+1} \quad \text{and} \quad \mathbf{C}_p = 2 - \mathbf{I}_p, \quad \text{for } 1 \leq i, k \leq p \quad (1.6)$$

are the incidence and Cartan matrix (respectively) of the Lie algebra  $A_p$  and the  $q$ -binomials are defined by

$$\left[ \begin{matrix} m+n \\ m \end{matrix} \right]_q = \begin{cases} \frac{(q)_{m+n}}{(q)_m (q)_n} & \text{for } m, n \text{ nonnegative integers} \\ 0 & \text{otherwise.} \end{cases} \quad (1.7)$$

The sum in (1.5) is defined to be the sum over all integers values of  $m_i$  with  $1 \leq i \leq p-2$  such that (1.7) is not zero and the component  $m_{p-2}$  has the additional restriction that  $m_{p-2} \equiv 0 \pmod{2}$ . These conventions will be followed in all sums in this paper. Since the incidence matrix  $\mathbf{I}_{p-2}$  is an important ingredient in the Thermodynamic Bethe Ansatz (TBA) equations for the  $\phi_{1,3}$  perturbation of  $M(p, p+1)$  models [11] it is natural to associate fermionic representation (1.5) with the perturbation  $\phi_{1,3}$

This identification of integrable perturbations with fermionic representations may be extended to the polynomial generalizations of the characters which are used to prove the identity of the fermionic and bosonic forms of the characters. As an example, the polynomial generalization of (1.1) used in [36] to prove (1.5) for the minimal conformal dimension (1.4) with  $|ps_m - p'r_m| = 1$  and  $L$  is even is the path counting formula of [4]-[5]

$$B(L, p, p') = \sum_{j=-\infty}^{\infty} \left( q^{j(pp'+1)} \left[ \begin{matrix} L \\ \frac{L}{2} - p'j \end{matrix} \right]_q - q^{(pj+r_m)(p'j+s_m)} \left[ \begin{matrix} L \\ \frac{L}{2} - jp' - s_m \end{matrix} \right]_q \right) \quad (1.8)$$

which if we use

$$\lim_{L \rightarrow \infty} \left[ \begin{matrix} L \\ \frac{L}{2} - a \end{matrix} \right]_q = \frac{1}{(q)_\infty} \quad (1.9)$$

reduces to (1.1) (with  $r = r_m$ ,  $s = s_m$ ) as  $L \rightarrow \infty$ . Similarly the polynomial generalization of the fermionic form in (1.5) is

$$F(L, p, p + 1) = \sum_{\substack{\mathbf{m} \\ m_{p-2} \equiv 0 \pmod{2}}} q^{\frac{1}{4}\mathbf{m} \mathbf{C}_{p-2} \mathbf{m}} \prod_{j=1}^{p-2} \left[ \begin{matrix} (\frac{1}{2}\mathbf{I}_{p-2} \mathbf{m} + \frac{L}{2}\mathbf{e}_1)_j \\ m_j \end{matrix} \right]_q \quad (1.10)$$

where we use the definition of the  $p - 2$  dimensional unit vectors  $(\mathbf{e}_j)_k = \delta_{j,k}$ . In the rest of this paper we will use  $\mathbf{e}_j$  for the  $j^{\text{th}}$  unit vector and assume that its dimension is clear from the context. The polynomial (1.10) reduces to the left hand side of (1.5) in the limit  $L \rightarrow \infty$  by use of

$$\lim_{L \rightarrow \infty} \left[ \begin{matrix} L \\ m \end{matrix} \right]_q = \frac{1}{(q)_m} \quad (1.11)$$

The character identity (1.5) itself thus generalizes to the polynomial identity

$$F(L, p, p + 1) = B(L, p, p + 1). \quad (1.12)$$

Polynomial analogues of Rogers-Ramanujan type identities have been obtained for all models  $M(p, p')$  [38], [39] and for all models where independent evidence exists [4]-[5],[11] these identities yield the particle content and are related to the TBA equations for the perturbation  $\phi_{1,3}$ .

The purpose of this paper is to extend these Rogers-Ramanujan studies from the  $\phi_{1,3}$  perturbations [36]-[39] to the perturbations  $\phi_{2,1}$  and  $\phi_{1,5}$  of the general models  $M(p, p')$ . For the  $\phi_{2,1}$  perturbation of  $M(p, p + 1)$  we then use these identities to conjecture a TBA which is identical with that of [25] for  $p = 4$ .

We also make the unexpected discovery that there are certain minimal models where one bosonic polynomial representation of the character may have several different fermionic representations. This is a phenomena not seen in any previous study. It seems significant that for the perturbations  $\phi_{2,1}$  and  $\phi_{1,5}$  the condition for these multiple representations of the polynomials to occur restricts  $p'/p$  to lie in precisely the regions where the study of vacuum expectation values [13] has not been carried out because of problems in identifying the correct vacuum. Thus our results provide some insight into the question of vacuum choice in quantum field theory.

Our method relies on the recently discovered [40], [41] trinomial analogue of Bailey's lemma plus additional results on trinomial representations of bosonic character polynomials. These results are summarized in sec. 2. In sec. 3 we study the case of  $\phi_{2,1}$

perturbations of  $M(p, p + 1)$  and make contact with the  $\phi_{2,1}$  perturbations studied in the dilute  $A_n$  models in [19]. In sec. 4 we relate our result to the recent TBA study [25] of  $M(4, 5)$  and use this to discuss possible TBA equations for the  $\phi_{2,1}$  perturbation of some other unitary models  $M(p, p + 1)$ . In sec. 5 we consider  $\phi_{1,5}$  perturbations of  $M(p, 3p - 1)$ . In sec. 6 we greatly extend our results to cover the  $\phi_{2,1}$  perturbations of almost all models  $M(p, p')$  with  $2p > p'$  and the  $\phi_{1,5}$  perturbations of most models  $M(p, p')$  with  $\frac{p'}{3} < p < \frac{p'}{2}$ . There are two special cases not included in sec. 6 which must be treated separately. In sec. 7 we discuss  $M(p, 2p \pm 2)$  for  $p \geq 5$  odd and from generalizations arising from this case we find in sec. 8 multiple fermionic representations of bosonic character polynomials for the  $\phi_{2,1}$  perturbation whenever  $3p < 2p'$  and for  $\phi_{1,5}$  with  $2 < p'/p \leq 5/2$ . In sec. 9 we cover the other special case  $M(p, 2p \pm 1)$  for  $p \geq 3$  and make contact with the work of [27]-[29]. We conclude in sec. 10 with a brief discussion of our results.

## 2. The Trinomial Bailey Lemma

The  $q$ -trinomials and the trinomial Bailey's lemma are generalizations of the well known  $q$ -binomials and the (binomial) Bailey lemma [44]. The  $q$ -binomials were defined by (1.7) and obey

$$\begin{bmatrix} m+n \\ m \end{bmatrix}_{q^{-1}} = q^{-mn} \begin{bmatrix} m+n \\ m \end{bmatrix}_q. \quad (2.1)$$

For the corresponding definition of  $q$ -trinomials we follow [45] and define

$$\begin{pmatrix} L; B; q \\ A \end{pmatrix}_2 = \sum_{j=0}^{\infty} \frac{q^{j(j+B)}(q)_L}{(q)_j(q)_{j+A}(q)_{L-2j-A}} = \sum_{j=0}^{\infty} q^{j(j+B)} \begin{bmatrix} L \\ 2j+A \end{bmatrix}_q \begin{bmatrix} 2j+A \\ j \end{bmatrix}_q \quad (2.2)$$

and

$$T_0(L, A; q) = q^{\frac{L^2-A^2}{2}} \begin{pmatrix} L; A; q^{-1} \\ A \end{pmatrix}_2. \quad (2.3)$$

In the sequel we will only need the case  $A = B$  and will suppress the argument  $B$  in (2.2). We refer to these as ‘‘round’’ trinomials. We will also suppress all arguments  $q$  when not needed.

The following properties of (round)  $q$ -trinomials

$$\begin{pmatrix} L \\ A \end{pmatrix}_2 = \begin{pmatrix} L \\ -A \end{pmatrix}_2 \quad (2.4)$$

$$T_0(L, A) = T_0(L, -A) \quad (2.5)$$

$$\lim_{L \rightarrow \infty} \binom{L}{A}_2 = \frac{1}{(q)_\infty} \quad (2.6)$$

$$\lim_{L \rightarrow \infty} T_0(L, A) = \begin{cases} \frac{(-q^{1/2})_\infty + (q^{1/2})_\infty}{2(q)_\infty} & \text{if } L - A \text{ is even} \\ \frac{(-q^{1/2})_\infty - (q^{1/2})_\infty}{2(q)_\infty} & \text{if } L - A \text{ is odd} \end{cases} \quad (2.7)$$

will be important in the sequel.

We say that the two sequences  $\alpha_n$  and  $\beta_n$  form a **trinomial Bailey pair** if

$$\beta_L = \sum_{j=0}^L \alpha_j \frac{T_0(L, j)}{(q)_L}. \quad (2.8)$$

Then from [40],[41] we have the following which we call the

### **Trinomial Analogue of Bailey's Lemma (TABL)**

$$\sum_{L=0}^{\infty} (\rho)_L (-1)^L q^{L/2} \rho^{-L} \beta_L = \frac{(q/\rho)_\infty^2}{(q)_\infty (q/\rho^2)_\infty} \sum_{n=0}^{\infty} \frac{(-1)^n q^{n/2} \rho^{-n} (\rho)_n \alpha_n}{(q/\rho)_n}. \quad (2.9)$$

The case  $\rho = -1$  was dealt with in [40] and is shown to lead to identities for the  $N = 2$  supersymmetric models. In this paper we consider the case  $\rho \rightarrow \infty$  where (2.9) reduces to

$$\sum_{L=0}^{\infty} q^{\frac{L^2}{2}} \beta_L = \frac{1}{(q)_\infty} \sum_{n=0}^{\infty} q^{\frac{n^2}{2}} \alpha_n. \quad (2.10)$$

### **3. The $\phi_{2,1}$ perturbation of $M(p, p+1)$ for $p \geq 4$**

In order to apply TABL (2.9) we need to start with a trinomial Bailey pair (2.8). As is the case with binomial Bailey pairs these pairs are often related to finitizations of some character identities. We thus begin our study by considering the polynomial identities found by Schilling [46],[47] for the coset model  $(A_1^{(1)})_2 \times (A_1^{(1)})_{p-3} / (A_1^{(1)})_{p-1}$  (the  $N = 1$  supersymmetric model  $SM(p-1, p+1)$  with  $p \geq 4$ )

$$\begin{aligned} & \sum_{\substack{\mathbf{m} \\ m_{p-2} \equiv (\text{mod } 2)}} q^{\frac{1}{4} \mathbf{m} C_{p-2} \mathbf{m}} \prod_{i=1}^{p-2} \left[ \begin{matrix} (\frac{1}{2} \mathbf{I}_{p-2} \mathbf{m} + \frac{\tilde{L}}{2} \mathbf{e}_2)_i \\ m_i \end{matrix} \right]_q \\ &= \sum_{j=-\infty}^{\infty} \left( q^{\frac{j}{2} (j(p+1)(p-1)+2)} T_0(\tilde{L}, (p+1)j) - q^{\frac{j}{2} ((p+1)j+1)((p-1)j+1)} T_0(\tilde{L}, (p+1)j+1) \right) \end{aligned} \quad (3.1)$$

with  $\mathbf{I}_{p-2}$  defined in (1.6). Together with the definition (2.8) this gives the trinomial Bailey pair

$$\beta_{\tilde{L}} = \frac{1}{(q)_{\tilde{L}}} \sum_{\substack{\mathbf{m} \\ m_{p-2} \equiv 0 \pmod{2}}} q^{\frac{1}{4}\mathbf{m}C_{p-2}\mathbf{m}} \prod_{i=1}^{p-2} \left[ \begin{matrix} (\frac{1}{2}\mathbf{I}_{p-2}\mathbf{m} + \frac{\tilde{L}}{2}\mathbf{e}_2)_i \\ m_i \end{matrix} \right]_q$$

$$\alpha_n = \begin{cases} q^{j(j(p+1)(p-1)+2)/2} & \text{for } j \geq 0, n = (p+1)j \\ q^{j(j(p+1)(p-1)-2)/2} & \text{for } j \geq 1, n = (p+1)j \\ -q^{((p+1)j+1)((p-1)j+1)/2} & \text{for } j \geq 0, n = (p+1)j + 1 \\ -q^{((p+1)j-1)((p-1)j-1)/2} & \text{for } j \geq 1, n = (p+1)j - 1 \end{cases} \quad (3.2)$$

To this pair we now apply the special case (2.10) of the TABL and obtain the identity

$$\sum_{\tilde{L}=0} \frac{q^{\frac{\tilde{L}^2}{2}}}{(q)_{\tilde{L}}} \sum_{\substack{\mathbf{m} \\ m_{p-2} \equiv 0 \pmod{2}}} q^{\frac{1}{4}\mathbf{m}C_{p-2}\mathbf{m}} \prod_{i=1}^{p-2} \left[ \begin{matrix} (\frac{1}{2}\mathbf{I}_{p-2}\mathbf{m} + \frac{\tilde{L}}{2}\mathbf{e}_2)_i \\ m_i \end{matrix} \right]_q$$

$$= \frac{1}{(q)_{\infty}} \sum_{j=-\infty}^{\infty} \left( q^{j(jp(p+1)+1)} - q^{(j(p+1)(j(p+1)+1)} \right) = \chi_{1,1}^{(p,p+1)}(q)$$
(3.3)

where in the last line we have made the identification with the bosonic character formula (1.1). However, even though the bosonic side of this identity is the same as the bosonic side of (1.5) the fermionic side is not. In particular the sum in (1.5) involves  $p-2$  variables while the  $q$ -series in the left hand side of (3.3) involves  $p-1$  variables. Thus the TABL has produced a new fermionic representation of the characters  $\chi_{1,1}^{(p,p+1)}(q)$  which we must now identify with some integrable perturbation.

The first step in the identification of the physical meaning of the  $q$ -series in (3.3) is to write it in the ‘‘canonical quasi-particle form’’ [33],[34] in terms of a single (possibly asymmetric) matrix  $B$  and a vector  $\mathbf{u}$  (which will in general have some infinite components)

$$F(\mathbf{u}) = \sum_{\substack{\mathbf{m} \\ \text{restrictions}}} q^{\frac{1}{2}\mathbf{m}B\mathbf{m}} \prod_j \left[ \begin{matrix} ((1 - \mathbf{B})\mathbf{m} + \mathbf{u})_j \\ m_j \end{matrix} \right]_q. \quad (3.4)$$

Such a representation is indeed possible if we set

$$\tilde{L} = m_0, \quad u_0 = \infty, \quad u_i = 0 \quad \text{for } i \neq 0 \quad (3.5)$$

and define the  $p-1 \times p-1$  dimensional matrices

$$\mathbf{B} = \frac{1}{2}\tilde{\mathbf{C}}_{p-1}, \quad \text{with } \tilde{\mathbf{C}}_{p-1} = 2 - \tilde{\mathbf{I}}_{p-1} \quad (3.6)$$

where

$$\tilde{\mathbf{I}}_{p-1} = \begin{pmatrix} 0 & 0 & -1 & 0 & 0 & \dots & 0 & 0 & 0 \\ 0 & 0 & 1 & 0 & 0 & \dots & 0 & 0 & 0 \\ 1 & 1 & 0 & 1 & 0 & \dots & 0 & 0 & 0 \\ 0 & 0 & 1 & 0 & 1 & \dots & 0 & 0 & 0 \\ 0 & 0 & 0 & 1 & 0 & \dots & 0 & 0 & 0 \\ \vdots & \vdots & \vdots & \vdots & \vdots & \ddots & \vdots & \vdots & \vdots \\ 0 & 0 & 0 & 0 & 0 & \dots & 1 & 0 & 1 \\ 0 & 0 & 0 & 0 & 0 & \dots & 0 & 1 & 0 \end{pmatrix} \quad (3.7)$$

This ‘‘incidence matrix’’ is represented graphically in Fig. 1 where we use the conventions that if sites  $a$  and  $b$  are connected by a line then  $(\tilde{\mathbf{I}}_{p-1})_{a,b} = (\tilde{\mathbf{I}}_{p-1})_{b,a} = 1$  and if  $a$  and  $b$  are joined by an arrow pointing from  $a$  to  $b$  then  $(\tilde{\mathbf{I}}_{p-1})_{a,b} = -(\tilde{\mathbf{I}}_{p-1})_{b,a} = -1$ . This convention will be used throughout the entire paper.

We now need to identify this  $q$ -series identity with a perturbation of  $M(p, p+1)$ . One way to do this is to consider the polynomial generalization of (3.3)

$$F_{2,1}(L, p, p+1) = B_1(L, p, p+1) \quad (3.8)$$

where

$$F_{2,1}(L, p, p+1) = \sum_{\mathbf{m}_{p-2} \equiv 0 \pmod{2}} q^{\frac{1}{4} \mathbf{m} \tilde{\mathbf{C}}_{p-1} \mathbf{m}} \prod_{j=0}^{p-2} \left[ \begin{matrix} (\frac{1}{2} \tilde{\mathbf{I}}_{p-1} \mathbf{m} + L \mathbf{e}_0)_j \\ m_j \end{matrix} \right]_q. \quad (3.9)$$

and

$$B_1(L, p, p') = \sum_{j=-\infty}^{\infty} \left( q^{j(pp'j + r_m p' - p s_m)} \binom{L}{2pj}_2 - q^{(jp + r_m)(jp' + s_m)} \binom{L}{2pj + 2r_m}_2 \right) \quad (3.10)$$

where

$$|p'r_m - ps_m| = 1 \quad (3.11)$$

which by use of (2.6) and (1.11) reduces to (3.3) as  $L \rightarrow \infty$ . We have verified that (3.8) holds by extensive computer checks. The polynomial (3.10) for  $p' = p+1$  appears in the calculation [19] of the order parameters of the dilute  $A_p$  models in regime  $1^\pm$  and corresponds to the  $\phi_{2,1}$  perturbations of  $M(p, p+1)$ . We will here generalize this and conclude that the trinomial generalization (3.10) of the character  $\chi_{r_m, s_m}^{(p, p')}(q)$  is the polynomial bosonic representation of the  $\phi_{2,1}$  perturbation of all models  $M(p, p')$  whenever  $2p > p'$  so that the perturbation is relevant. We also note that an identity somewhat similar to (3.8) appeared in [42] as eqn. (5.1) and was proven in [43]. The right hand side of that equation is indeed the same as the right hand side of (3.8). However, the left hand

side of the identity of [42] is not the same as (3.9). In particular we note: (1) for finite  $L$  the fermionic form of [42] is not in the canonical form (3.4) which has a quasi-particle interpretation; and (2) in the limit  $L \rightarrow \infty$  the fermionic form of [42] is identical with (1.5) and not with the left hand side of (3.3).

#### 4. A TBA conjecture for the $\phi_{2,1}$ perturbation of $M(p, p+1)$ for $p \geq 4$

The incidence matrix  $\tilde{\mathbf{I}}_{p-1}$  (3.7) for  $p = 4$  has an important connection with the TBA computations for the model  $M(4, 5)$  perturbed by  $\phi_{2,1}$  recently done by Ellem and Bazhanov [25]. In this section we explain this connection and use it to conjecture a system of TBA equations for more general case of the model  $M(p, p+1)$ .

To explain the connection we rewrite the fermionic polynomial (3.9) in terms of what is called an  $m, n$  system as follows

$$F_{2,1}(L, p, p+1) = \sum_{\substack{\mathbf{m} \\ m_{p-2} \equiv 0 \pmod{2}}} q^{\frac{1}{4}\mathbf{m}\tilde{\mathbf{C}}_{p-1}\mathbf{m}} \prod_{j=0}^{p-2} \begin{bmatrix} m_j + n_j \\ m_j \end{bmatrix} \quad (4.1)$$

where

$$\mathbf{n} + \mathbf{m} = \frac{1}{2}\tilde{\mathbf{I}}_{p-1}\mathbf{m} + L\mathbf{e}_0 \quad (4.2)$$

and  $m_i$  and  $n_i$  are nonnegative integers. To make contact with [25] we specialize to the case  $p = 4$  to find

$$\begin{aligned} n_0 + m_0 &= L - \frac{1}{2}m_2 \\ n_2 + m_2 &= \frac{1}{2}(m_0 + m_1) \\ n_1 + m_1 &= \frac{m_2}{2}. \end{aligned} \quad (4.3)$$

This system is identical with the corresponding system which may be obtained from (3.13)-(3.16) of [25] by integrating (3.13) of [25] on  $\theta$  and using the notation

$$\int d\theta \sigma_k(\theta) = m_k, \quad \text{and} \quad \int d\theta \tilde{\sigma}_k(\theta) = n_k \quad (4.4)$$

and letting

$$\frac{m}{2\pi} \int d\theta \cosh \theta \rightarrow L \quad (4.5)$$

where we note that the sign factor  $s_0 = -1$  in [25] corresponds to the asymmetry present in the matrix  $\tilde{\mathbf{I}}_{p-1}$  of (3.7).

From these considerations it is natural to try to extend the TBA equations of [25] for  $M(4, 5)$  to  $M(p, p + 1)$  by writing the following set

$$\epsilon_j(\theta) = \delta_{j,0} r \cosh \theta + \sum_{k=0}^{p-2} \int_{-\infty}^{\infty} \Phi_{j,k}(\theta - \theta') \ln(1 + e^{-\epsilon_k(\theta')}) d\theta', \quad j = 0, 1, \dots, p-2 \quad (4.6)$$

with the ground state scaling function  $c(r, p)$  given by

$$\frac{\pi c(r, p)}{6r} = \frac{1}{2\pi} \int_{-\infty}^{\infty} \cosh \theta \ln(1 + e^{-\epsilon_0(\theta)}) d\theta \quad (4.7)$$

where

$$\Phi_{j,k}(\theta) = -\psi_{j,k}(\theta) (\tilde{\mathbf{I}}_{p-1}^t)_{j,k} - \delta_{j,0} \delta_{k,0} \tilde{\psi}_1(\theta) \quad (4.8)$$

and in order to assure that

$$c(0, p) = 1 - \frac{6}{p(p+1)} \quad (4.9)$$

we require that

$$\int_{-\infty}^{\infty} \psi_{j,k}(\theta) d\theta = \frac{1}{2} |(\tilde{\mathbf{I}}_{p-1}^t)_{j,k}|, \quad \int_{-\infty}^{\infty} \tilde{\psi}_1(\theta) = 0. \quad (4.10)$$

These requirements are sufficient to guarantee that as  $r \rightarrow \infty$

$$\frac{\pi c(r)}{6r} = \frac{\sin \frac{3\pi}{p+1}}{2\pi \sin \frac{\pi}{p+1}} \int_{-\infty}^{\infty} d\theta e^{-r \cosh \theta} d\theta + O(e^{-2r}) \quad (4.11)$$

which agrees with the result (3.19) of [48] with  $p \rightarrow -p - 1$ .

Further information on the functions  $\psi_{i,j}$  and  $\tilde{\psi}_1$  may be obtained by demanding agreement of  $c(r)$  to order  $r^2$  as  $r \rightarrow 0$  (known as the bulk term) with the result (3.15) of [48] with  $p \rightarrow -p - 1$  and by demanding that the periodicity of (4.6) will be consistent with the anomalous dimensions of the perturbation  $\phi_{2,1}$ . We have found for all  $p$  candidates for  $\psi_{j,k}$  and  $\tilde{\psi}_1$  which satisfy these requirements. Further tests are needed to determine which (if any) of these candidates fully agree with conformal perturbation theory. Details will be given elsewhere.

## 5. The $\phi_{1,5}$ perturbation of $M(p, 3p - 1)$ for $p \geq 4$

In sec. 3 we went from the identities (3.1) for the models  $SM(p - 1, p + 1)$  to the identities (3.8) for the models  $M(p, p + 1)$ . Remarkably we may apply the TABL once again if we first send  $q \rightarrow 1/q$  in the polynomial identity (3.8) and use (2.3) with  $n = 0$  to convert the round trinomials into  $T_0$  so that a trinomial Bailey pair may be extracted using the definition (2.8). Thus applying (2.10) once again we have the new identity

$$\sum_{\tilde{L}=0}^{\infty} \sum_{\substack{\mathbf{m} \\ m_{p-2} \equiv 0 \pmod{2}}} q^{\tilde{L}^2 - \tilde{L}m_0 + \frac{1}{4}\mathbf{m}\tilde{\mathbf{C}}_{p-1}\mathbf{m}} \frac{1}{(q)_{\tilde{L}}} \prod_{j=0}^{p-2} \left[ \begin{matrix} (\frac{1}{2}\tilde{\mathbf{I}}_{p-1}\mathbf{m} + \tilde{L}\mathbf{e}_0)_j \\ m_j \end{matrix} \right]_q = \chi_{1,3}^{(p,3p-1)}(q) \quad (5.1)$$

We again want to generalize this to a polynomial which we do by first replacing in (5.1)  $\tilde{L} \rightarrow n_{-1}$  and then letting

$$\frac{1}{(q)_{n_{-1}}} \rightarrow \left[ \begin{matrix} L - n_{-1} + m_0 \\ n_{-1} \end{matrix} \right]_q \quad (5.2)$$

to define a polynomial

$$F_{1,5}(L, p, 3p-1) = \sum_{\substack{n_{-1}, \mathbf{m} \\ m_{p-2} \equiv 0 \pmod{2}}} q^{n_{-1}^2 - n_{-1}m_0 + \frac{1}{4}\mathbf{m}\tilde{\mathbf{C}}_{p-1}\mathbf{m}} \left[ \begin{matrix} L - n_{-1} + m_0 \\ n_{-1} \end{matrix} \right]_q \prod_{j=0}^{p-2} \left[ \begin{matrix} (\frac{1}{2}\tilde{\mathbf{I}}_{p-1}\mathbf{m} + n_{-1}\mathbf{e}_0)_j \\ m_j \end{matrix} \right]_q. \quad (5.3)$$

Next we introduce incidence matrix  $\mathbf{I}'_p$  which is obtained from a new  $m, n$  system

$$\begin{aligned} n_{-1} + m_{-1} &= \frac{1}{2}(m_{-1} + m_0 + L) \\ n_0 + m_0 &= \frac{1}{2}(-m_{-1} + m_0 - m_2 + L) \\ n_1 + m_1 &= \frac{1}{2}m_2 \\ n_2 + m_2 &= \frac{1}{2}(m_1 + m_0 + m_3) \\ n_j + m_j &= \frac{1}{2}(m_{j-1} + m_{j+1}) \quad \text{for } 3 \leq j \leq p-3 \\ n_{p-2} + m_{p-2} &= \frac{1}{2}m_{p-3} \end{aligned} \quad (5.4)$$

as

$$\mathbf{m} + \mathbf{n} = \frac{1}{2}\mathbf{I}'_p\mathbf{m} + \frac{L}{2}(\mathbf{e}_0 + \mathbf{e}_{-1}). \quad (5.5)$$

This incidence matrix is shown graphically in Fig. 2. Then we may rewrite (5.3) as

$$F_{1,5}(L, p, 3p-1) = \sum_{\substack{\mathbf{m} \\ m_{p-2} \equiv 0 \pmod{2}}} q^{\frac{1}{4}((\mathbf{m}-L\mathbf{e}_{-1})\mathbf{C}'_p(\mathbf{m}-L\mathbf{e}_{-1}))} \prod_{j=-1}^{p-2} \left[ \begin{matrix} (\frac{1}{2}\mathbf{I}'_p\mathbf{m} + \frac{L}{2}(\mathbf{e}_{-1} + \mathbf{e}_0))_j \\ m_j \end{matrix} \right]_q \quad (5.6)$$

where  $\mathbf{C}'_p = 2 - \mathbf{I}'_p$ . If we now define

$$B_2(L, p, p') = \sum_{j=-\infty}^{\infty} \left( q^{j(pp'j+r_m p' - ps_m)} \binom{L}{p'j}_2 - q^{(jp+r_m)(jp'+s_m)} \binom{L}{p'j+s_m}_2 \right) \quad (5.7)$$

with  $r_m$  and  $s_m$  as given in (3.11) we find from extensive computer studies a polynomial generalization of the identity (5.1)

$$F_{1,5}(L, p, 3p-1) = B_2(L, p, 3p-1). \quad (5.8)$$

It now remains to associate the identities (5.1) and (5.8) with a relevant perturbation of the model  $M(p, 3p-1)$ . For this model the perturbation  $\phi_{2,1}$  is not relevant because  $2p < p'$  (where here  $p' = 3p-1$ ). On the other hand the integrable perturbation  $\phi_{1,5}$  is relevant for  $2p < p'$  and by generalizing the ‘‘duality’’ seen in [28]-[29] between  $\phi_{2,1}$  and  $\phi_{1,5}$  we identify the bosonic polynomial (5.7) in general with the  $\phi_{1,5}$  perturbation. This identification is discussed further in sec. 9 where we study the cases  $M(p, 2p \pm 1)$  of [29] and can be tested by computing the order parameter for the models of Kuniba [20].

## 6. Generalizations

In the preceding sections we have examined a particularly simple application of the TABL. However from that work it is apparent that many generalizations are possible.

### 6.1. The perturbation $\phi_{2,1}$ of $M(p, p')$ for $1 < p'/p < 3/2$ .

For our first generalization we note that instead of taking as our starting point the polynomial identities (3.1) for the models  $(A_1^{(1)})_2 \times (A_1^{(1)})_{p-3}/(A_1^{(1)})_{p-1}$  with  $p \geq 4$  an integer as done in sec. 3 we can start with the corresponding polynomial identities for  $p$  fractional which are derived in [49] from the identities for the models  $M(p, p')$  of [38]-[39]. In sec. 5 of [49] the polynomial identity is proven which generalizes (3.1)

$$F^{(2)}(L, p, p') = B^{(2)}(L, p, p') \quad \text{for } 2p' < 3p \quad (6.1)$$

where

$$B^{(2)}(L, p, p') = \sum_{j=-\infty}^{\infty} (q^{\frac{j}{2}[p'(2p-p')j+p'r_0-(2p-p')s_m]} T_0(L, p'j) - q^{\frac{1}{2}(p'j+s_m)((2p-p')j+r_0)} T_0(L, p'j + s_m)) \quad (6.2)$$

with

$$r_0 = 2r_m - s_m, \quad \text{and} \quad |p'r_m - ps_m| = 1 \quad (6.3)$$

and

$$F^{(2)}(L, p, p') = \sum_{\substack{\mathbf{m} \\ m_{t_f} \equiv (\text{mod } 2)}} q^{\frac{1}{4}\mathbf{m}C^{(2)}(p, p')\mathbf{m}} \prod_{j=1}^{t_f} \left[ \begin{matrix} (\frac{1}{2}\mathbf{I}^{(2)}(p, p')\mathbf{m} + \frac{L}{2}\mathbf{e}_2)_j \\ m_j \end{matrix} \right]_q. \quad (6.4)$$

with

$$\mathbf{C}^{(2)}(p, p') = 2 - \mathbf{I}^{(2)}(p, p'). \quad (6.5)$$

This identity is completed by specifying the incidence matrix  $\mathbf{I}^{(2)}(p, p')$ . This is done by first introducing the continued fraction decomposition

$$\frac{p'}{p' - p} = 1 + \nu_0 + \frac{1}{\nu_1 + \frac{1}{\nu_2 + \dots + \frac{1}{2 + \nu_f}}} \quad (6.6)$$

with  $f \geq 1$  and  $\nu_0 \geq 2$  which defines the numbers  $\nu_j$ . From this we define for  $f \geq 1$

$$t_l = \sum_{j=0}^l \nu_j, \quad 0 \leq l \leq f \quad (6.7)$$

and the incidence matrix  $\mathbf{I}^{(2)}(p, p')$  which is given graphically in Fig. 3

$$\begin{aligned} (\mathbf{I}^{(2)}(p, p'))_{1,i} &= \delta_{1,i-1} \\ (\mathbf{I}^{(2)}(p, p'))_{j,i} &= \delta_{j,i+1} + \delta_{j,i-1} \quad \text{for } j \neq 1, t_l \quad 0 \leq l \leq f \\ (\mathbf{I}^{(2)}(p, p'))_{t_l,i} &= \delta_{t_l,i+1} + \delta_{t_l,i} - \delta_{t_l,i-1} \quad \text{for } 0 \leq l \leq f-1 \\ (\mathbf{I}^{(2)}(p, p'))_{t_f,i} &= \delta_{t_f,i+1} + \delta_{\nu_f,0} \delta_{t_f,i} \end{aligned} \quad (6.8)$$

with  $1 \leq i, j \leq t_f$ . In the case where  $\nu_f = 0$  the last equation in (6.8) is given precedence over the next to last equation with  $l = f - 1$ .

The TABL may now be applied in the identical manner as for the case  $f = 0$  which was considered in sec. 3 and the finitization of the resulting fermi-bose identity may be made

again (and verified in low order cases on the computer). Thus we find the generalization of (3.8) to the model  $M(p, p')$  with  $3p > 2p'$

$$F_{2,1}(L, p, p') = B_1(L, p, p') \quad (6.9)$$

where

$$F_{2,1}(L, p, p') = \sum_{\substack{\mathbf{m} \\ m_{t_f} \equiv 0 \pmod{2}}} q^{\frac{1}{4}\mathbf{m}\tilde{\mathbf{C}}^{(2,1)}(p,p')\mathbf{m}} \prod_{j=0}^{t_f} \left[ \begin{matrix} (\frac{1}{2}\tilde{\mathbf{I}}^{(2,1)}(p,p')\mathbf{m} + L\mathbf{e}_0)_j \\ m_j \end{matrix} \right]_q \quad (6.10)$$

where  $\tilde{\mathbf{C}}^{(2,1)}(p, p') = 2 - \tilde{\mathbf{I}}^{(2,1)}(p, p')$  and the incidence matrix shown graphically in Fig. 4 is

$$\begin{aligned} (\tilde{\mathbf{I}}^{(2,1)}(p, p'))_{0,i} &= -(\tilde{\mathbf{I}}^{(2,1)}(p, p'))_{i,0} = -\delta_{i,2} \text{ for } 0 \leq i \leq t_f \\ (\tilde{\mathbf{I}}^{(2,1)}(p, p'))_{j,i} &= (\mathbf{I}^{(2)}(p, p'))_{j,i} \text{ for } 1 \leq j, i \leq t_f. \end{aligned} \quad (6.11)$$

We refer to this region where  $3p > 2p'$  as the region of weak anisotropy for the  $\phi_{2,1}$  perturbation and in this region the result (6.9) covers all cases. In this region the central charge lies in the interval  $-2 < c < 0$ . This is the region studied in [13] where there are no vacuum ambiguities.

## 6.2. The perturbation $\phi_{1,5}$ for $M(p, 4p - p')$ for $3p > 2p'$

For the second generalization we apply TABL to the trinomial identity (6.9) just as we applied TABL to (3.8) in sec. 5 and thus we obtain for the models  $M(p, 4p - p')$  with  $3p > 2p'$  the following extension of (5.8)

$$F_{1,5}(L, p, 4p - p') = B_2(L, p, 4p - p') \quad (6.12)$$

where

$$\begin{aligned} &F_{1,5}(L, p, 4p - p') \\ &= \sum_{\substack{\mathbf{m} \\ m_{t_f} \equiv 0 \pmod{2}}} q^{\frac{1}{4}(L(L-2m_{-1})+\mathbf{m}\tilde{\mathbf{C}}^{(1,5)}(p,p')\mathbf{m})} \prod_{j=-1}^{t_f} \left[ \begin{matrix} (\frac{1}{2}(\tilde{\mathbf{I}}^{(1,5)}(p,p')\mathbf{m} + L(\mathbf{e}_{-1} + \mathbf{e}_0))_j \\ m_j \end{matrix} \right]_q, \end{aligned} \quad (6.13)$$

$\tilde{\mathbf{C}}^{(1,5)}(p, p') = 2 - \tilde{\mathbf{I}}^{(1,5)}(p, p')$  and incidence matrix  $\tilde{\mathbf{I}}^{(1,5)}(p, p')$ , given graphically in Fig. 5, is

$$\begin{aligned} (\tilde{\mathbf{I}}^{(1,5)}(p, p'))_{-1,-1} &= (\tilde{\mathbf{I}}^{(1,5)}(p, p'))_{-1,0} = -(\tilde{\mathbf{I}}^{(1,5)}(p, p'))_{0,-1} = 1 \\ (\tilde{\mathbf{I}}^{(1,5)}(p, p'))_{j,i} &= (\tilde{\mathbf{I}}^{(2,1)}(p, p'))_{j,i} + \delta_{j,0}\delta_{i,0}, \text{ for } 0 \leq j, i \leq t_f \end{aligned} \quad (6.14)$$

and zero otherwise.  $\tilde{\mathbf{I}}^{(2,1)}(p, p')$  was defined in (6.11).

6.3. Further generalizations for the perturbations  $\phi_{2,1}$  and  $\phi_{5,1}$ .

We have now generalized the starting point of secs. 3 and 5 and obtained identities for a wide class of models. However since the identity (6.12) is also in the form (2.8) the TABL may be applied again to obtain a new identity whose finitizations can be conjectured and tested on the computer. As long as the conjectured finitizations are of the form (2.8) the process may be continued indefinitely and alternately produces fermionic representations for  $\phi_{2,1}$  and  $\phi_{1,5}$  perturbations. The two new feature of this procedure is that “triangles” appear in the incidence matrices and there are “negative tadpoles” for  $\phi_{2,1}$  perturbation. The results are as follows:

**A. The  $\phi_{2,1}$  perturbations for  $M(\bar{p}, \bar{p}')$  with  $3/2 < \bar{p}'/\bar{p} < 2$ ,  $\bar{p}' \neq 2\bar{p} - 2$**

We define  $\bar{p}', \bar{p}$  from  $p', p$  of (6.6) and an integer  $n$  by

$$\frac{\bar{p}'}{\bar{p} - \bar{p}} = 2 + \frac{1}{n + \frac{1}{\frac{p'}{p'} - 2}}, \quad \text{where } n = 1, 2, 3, \dots \text{ and } \frac{p'}{p' - p} > 3, \frac{p'}{p' - p} \neq 4. \quad (6.15)$$

Next we introduce the  $2n + 1 + t_f$  dimensional incidence matrix  $\mathbf{J}^{(2,1)}(\bar{p}, \bar{p}')$  (Fig. 6) as

$$\begin{aligned} (\mathbf{J}^{(2,1)}(\bar{p}, \bar{p}'))_{-2n, i} &= -\delta_{-2n, i} - \delta_{-2n+1, i} + \delta_{-2n+2, i} \\ (\mathbf{J}^{(2,1)}(\bar{p}, \bar{p}'))_{i, -2n} &= -\delta_{-2n, i} + \delta_{-2n+1, i} + \delta_{-2n+2, i} \\ (\mathbf{J}^{(2,1)}(\bar{p}, \bar{p}'))_{-2l, i} &= -\delta_{-2l+1, i} - \delta_{-2l-1, i} + \delta_{-2l-2, i} + \delta_{-2l+2, i} \text{ for } l = 1, 2, \dots, n-1 \\ (\mathbf{J}^{(2,1)}(\bar{p}, \bar{p}'))_{i, -2l} &= +\delta_{-2l+1, i} + \delta_{-2l-1, i} + \delta_{-2l-2, i} + \delta_{-2l+2, i} \text{ for } l = 1, 2, \dots, n-1 \\ (\mathbf{J}^{(2,1)}(\bar{p}, \bar{p}'))_{-2l-1, i} &= \delta_{-2l-2, i} + \delta_{-2l-1, i} + \delta_{-2l, i} \text{ for } l = 0, 1, \dots, n-1 \\ (\mathbf{J}^{(2,1)}(\bar{p}, \bar{p}'))_{i, -2l-1} &= -\delta_{-2l-2, i} + \delta_{-2l-1, i} - \delta_{-2l, i} \text{ for } l = 0, 1, \dots, n-1 \\ (\mathbf{J}^{(2,1)}(\bar{p}, \bar{p}'))_{0, i} &= -\delta_{2, i} + \delta_{0, i} - \delta_{-1, i} + \delta_{-2, i} \\ (\mathbf{J}^{(2,1)}(\bar{p}, \bar{p}'))_{i, 0} &= \delta_{2, i} + \delta_{0, i} + \delta_{-1, i} + \delta_{-2, i} \end{aligned} \quad (6.16)$$

for  $-2n \leq i \leq t_f$

$$(\mathbf{J}^{(2,1)}(\bar{p}, \bar{p}'))_{j, i} = (\tilde{\mathbf{I}}^{(2,1)}(p, p'))_{j, i} \text{ for } 1 \leq j, i \leq t_f \quad (6.17)$$

and  $\mathbf{C}^{(2,1)}(\bar{p}, \bar{p}') = 2 - \mathbf{J}^{(2,1)}(\bar{p}, \bar{p}')$  where  $\tilde{\mathbf{I}}^{(2,1)}(p, p')$  is given by (6.11). Then defining the fermionic form

$$F_{2,1}(L, \bar{p}, \bar{p}') = \sum_{\substack{\mathbf{m} \\ m_{t_f} \equiv 0 \pmod{2}}} q^{\frac{1}{4} \mathbf{m} \mathbf{C}^{(2,1)}(\bar{p}, \bar{p}') \mathbf{m}} \prod_{j=-2n}^{t_f} \left[ \begin{matrix} (\frac{1}{2} \mathbf{J}^{(2,1)}(\bar{p}, \bar{p}') \mathbf{m} + L \mathbf{e}_{-2n})_j \\ m_j \end{matrix} \right] \quad (6.18)$$

and recalling (3.10) we have the polynomial identity

$$F_{2,1}(L, \bar{p}, \bar{p}') = B_1(L, \bar{p}, \bar{p}'). \quad (6.19)$$

**B. The  $\phi_{1,5}$  perturbations for  $M(\bar{p}, \bar{p}')$  with  $2 < \bar{p}'/\bar{p} < 5/2$ ,  $\bar{p}' \neq 2\bar{p} + 2$**

In the case of the  $\phi_{1,5}$  perturbation, generalization is made in a similar fashion, now by defining  $\bar{p}'$  and  $\bar{p}$  as

$$\frac{\bar{p}'}{\bar{p}} = 2 + \frac{1}{n+1 + \frac{1}{\frac{p'}{p}-2}}, \quad \text{where } n = 1, 2, 3, \dots \text{ and } \frac{p'}{p} > 3, \frac{p'}{p} \neq 4. \quad (6.20)$$

Then we introduce the  $2n + 2 + t_f$  dimensional incidence matrix  $\mathbf{J}^{(1,5)}(\bar{p}, \bar{p}')$  (Fig. 7) as

$$(\mathbf{J}^{(1,5)}(\bar{p}, \bar{p}'))_{j,i} = (\mathbf{J}^{(2,1)}(\bar{p}' - \bar{p}, \bar{p}'))_{j,i} \quad -2n - 1 \leq j, i \leq t_f \quad (6.21)$$

$\mathbf{C}^{(1,5)}(\bar{p}, \bar{p}') = 2 - \mathbf{J}^{(1,5)}(\bar{p}, \bar{p}')$  and the fermionic form

$$\begin{aligned} & F_{1,5}(L, \bar{p}, \bar{p}') \\ &= \sum_{\substack{\mathbf{m} \\ m_{t_f} \equiv 0 \pmod{2}}} q^{\frac{1}{4}(L(L-2m_{-2n-1}) + \mathbf{m} \mathbf{C}^{(1,5)}(\bar{p}, \bar{p}') \mathbf{m})} \prod_{j=-1-2n}^{t_f} \left[ \frac{1}{2} (\mathbf{J}^{(1,5)}(\bar{p}, \bar{p}') \mathbf{m} + L(\mathbf{e}_{-1-2n} + \mathbf{e}_{-2n}))_j \right]_q. \end{aligned} \quad (6.22)$$

The appropriate polynomial identity is

$$F_{1,5}(L, \bar{p}, \bar{p}') = B_2(L, \bar{p}, \bar{p}'). \quad (6.23)$$

**7. The model  $M(2\nu + 1, 2(2\nu + 1) \pm 2)$  for  $\nu \geq 2$**

In this section we consider the important special case omitted from the discussion of the previous section:  $p'/(p' - p) = 4$  in the continued fractions (6.15) and (6.20). For this case we need to find a new starting trinomial identity to replace (6.1). Fortunately such an identity has been derived in [50] where the polynomial analogues of the generalized Göllnitz-Gordon identities for the  $N = 1$  supersymmetric model  $SM(2, 4\nu)$  were derived. We will show that the direct application of the TABL to the trinomial Bailey pair of [50] will lead to the model  $M(2\nu+1, 4\nu)$  which corresponds to the special case  $p'/(p' - p) = 4$  in (6.15).

In [50] it was proven that with

$$B^{N=1}(L, 2, 4\nu) = \sum_{j=-\infty}^{\infty} (-1)^j q^{\nu j^2 + \frac{j}{2}} (T_0(L, 2\nu j) + T_0(L, 2\nu j + 1)), \quad (7.1)$$

the incidence matrix  $\mathbf{I}(2, 4\nu)(= \mathbf{I}^{(2)}(2\nu + 1, 4\nu))$  of Fig. 8 defined by

$$\begin{aligned} (\mathbf{I}(2, 4\nu))_{1,k} &= \delta_{1,k} - \delta_{2,k} \\ (\mathbf{I}(2, 4\nu))_{j,k} &= \delta_{j-1,k} + \delta_{j+1,k} \quad \text{for } 2 \leq j \leq \nu - 1 \\ (\mathbf{I}(2, 4\nu))_{\nu,k} &= \delta_{\nu-1,k} + \delta_{\nu,k}, \end{aligned} \quad (7.2)$$

where  $1 \leq k \leq \nu$ , the matrix  $\mathbf{C}(2, 4\nu) = 2 - \mathbf{I}(2, 4\nu)$ , and the fermionic form

$$F^{N=1}(L, 2, 4\nu) = \sum_{\mathbf{m}} q^{\frac{1}{4}(L(L-2m_2) + \mathbf{m}\mathbf{C}(2,4\nu)\mathbf{m})} \prod_{j=1}^{\nu} \left[ \begin{array}{c} \frac{1}{2}(\mathbf{I}(2, 4\nu)\mathbf{m} + L(\mathbf{e}_1 + \mathbf{e}_2))_j \\ m_j \end{array} \right]_q \quad (7.3)$$

we have the polynomial identity for  $\nu \geq 2$

$$F^{N=1}(L, 2, 4\nu) = B^{N=1}(L, 2, 4\nu). \quad (7.4)$$

This identity is exactly in the form (2.8) needed for the TABL and thus we find from (2.10) the character identity for the model  $M(2\nu + 1, 4\nu)$

$$\begin{aligned} \sum_{\tilde{L}, \mathbf{m}} q^{\frac{\tilde{L}^2}{2} + \frac{1}{4}(\tilde{L}(\tilde{L}-2m_2) + \mathbf{m}\mathbf{C}(2,4\nu)\mathbf{m})} \frac{1}{(q)_{\tilde{L}}} \prod_{j=1}^{\nu} \left[ \begin{array}{c} \frac{1}{2}(\mathbf{I}(2, 4\nu)\mathbf{m} + \tilde{L}(\mathbf{e}_1 + \mathbf{e}_2))_j \\ m_j \end{array} \right]_q \\ = \chi_{\nu+1, 2\nu+1}^{(2\nu+1, 4\nu)}(q) + q^{\frac{1}{2}} \chi_{\nu, 2\nu+1}^{(2\nu+1, 4\nu)}(q). \end{aligned} \quad (7.5)$$

Because the right hand side contains both integer and half integer powers of  $q^{\frac{1}{2}}$  we may split this identity into two identities for the characters  $\chi_{\nu+1, 2\nu+1}^{(2\nu+1, 4\nu)}(q)$  and  $\chi_{\nu, 2\nu+1}^{(2\nu+1, 4\nu)}(q)$  separately and we find

$$\begin{aligned} \sum_{\substack{\tilde{L}, \mathbf{m} \\ m_{\nu} \equiv 0 \pmod{2}}} q^{\frac{\tilde{L}^2}{2} + \frac{1}{4}(\tilde{L}(\tilde{L}-2m_2) + \mathbf{m}\mathbf{C}(2,4\nu)\mathbf{m})} \frac{1}{(q)_{\tilde{L}}} \prod_{j=1}^{\nu} \left[ \begin{array}{c} \frac{1}{2}(\mathbf{I}(2, 4\nu)\mathbf{m} + \tilde{L}(\mathbf{e}_1 + \mathbf{e}_2))_j \\ m_j \end{array} \right]_q \\ = \chi_{\nu+1, 2\nu+1}^{(2\nu+1, 4\nu)}(q) \end{aligned} \quad (7.6)$$

and similarly for  $\chi_{\nu, 2\nu+1}^{(2\nu+1, 4\nu)}(q)$  with  $m_{\nu} \equiv 1 \pmod{2}$ .

We may now finitize this character formula as in previous sections by defining  $\mathbf{I}^{(2,1)}(\nu)$  (Fig. 9) as

$$\begin{aligned} (\mathbf{I}^{(2,1)}(\nu))_{0,k} &= -\delta_{0,k} - \delta_{1,k} + \delta_{2,k}; \quad (\mathbf{I}^{(2,1)}(\nu))_{k,0} = -\delta_{0,k} + \delta_{1,k} + \delta_{2,k} \text{ for } 0 \leq k \leq \nu \\ (\mathbf{I}^{(2,1)}(\nu))_{j,k} &= (\mathbf{I}(2, 4\nu))_{j,k} \text{ for } 1 \leq j, k \leq \nu \end{aligned} \quad (7.7)$$

$\mathbf{C}^{(2,1)}(\nu) = 2 - \mathbf{I}^{(2,1)}(\nu)$  and write the polynomial identity which has been checked to high order on the computer

$$\sum_{\substack{\mathbf{m} \\ m_\nu \equiv 0 \pmod{2}}} q^{\frac{1}{4}\mathbf{m}\mathbf{C}^{(2,1)}(\nu)\mathbf{m}} \prod_{j=0}^{\nu} \left[ \begin{matrix} (\frac{1}{2}\mathbf{I}^{(2,1)}(\nu)\mathbf{m} + L\mathbf{e}_0) \\ m_j \end{matrix} \right]_q = B_1(L, 2\nu + 1, 4\nu) \quad (7.8)$$

Thus we have the polynomial identity for the  $\phi_{2,1}$  perturbation of model  $M(2\nu + 1, 4\nu)$ .

Since (7.8) is of the form (2.8) we may now apply the TABL once again and make a finitization to obtain the identity for the  $\phi_{1,5}$  perturbation of  $M(2\nu + 1, 4\nu + 4)$

$$\begin{aligned} \sum_{\substack{\mathbf{m} \\ m_\nu \equiv 0 \pmod{2}}} q^{\frac{1}{4}(L(L-2m_{-1})+\mathbf{m}\mathbf{C}^{(1,5)}(\nu)\mathbf{m})} \prod_{j=-1}^{\nu} \left[ \begin{matrix} (\frac{1}{2}\mathbf{I}^{(1,5)}(\nu)\mathbf{m} + \frac{L}{2}(\mathbf{e}_0 + \mathbf{e}_{-1})) \\ m_j \end{matrix} \right]_q \\ = B_2(L, 2\nu + 1, 4\nu + 4) \end{aligned} \quad (7.9)$$

where  $\mathbf{I}^{(1,5)}(\nu)$  (Fig. 10) is

$$\begin{aligned} (\mathbf{I}^{(1,5)}(\nu))_{-1,i} &= \delta_{-1,i} + \delta_{0,i}; \quad (\mathbf{I}^{(1,5)}(\nu))_{i,-1} = \delta_{-1,i} - \delta_{0,i} \text{ for } -1 \leq i \leq \nu \\ (\mathbf{I}^{(1,5)}(\nu))_{j,i} &= (\mathbf{I}^{(2,1)}(\nu))_{j,i} + \delta_{j,0}\delta_{i,0} \text{ for } 0 \leq i, j \leq \nu \end{aligned} \quad (7.10)$$

with  $\mathbf{I}^{(2,1)}(\nu)$  given by (7.7) and  $\mathbf{C}^{(1,5)}(\nu) = 2 - \mathbf{I}^{(1,5)}(\nu)$ .

## 8. Families of identities

We now have found identities for the  $\phi_{2,1}$  perturbation of  $M(p, 2p - 2)$  and the  $\phi_{1,5}$  perturbation of  $M(p, 2p + 2)$  for all  $p \geq 5$  and thus have found the identities for the special case  $p'/(p' - p) = 4$  in (6.15) and (6.20). However, this is not the end of the story. Just as in the previous section we could continue to apply the TABL followed by finitization of the resulting identity to produce an infinite chain of identities. Only now the identities will be for models which have been seen before for which we already had produced an identity and moreover the new identity we will produce will have a different number of variables from the old identity. This is new a phenomena not previously encountered which gives different fermionic representations for the same bosonic polynomial. We refer to it as “families of identities”.

8.1. The  $\phi_{2,1}$  perturbation of  $M(2(\nu + n) + 1, 4(\nu + n))$

As our first example of such a family we find for the  $\phi_{2,1}$  perturbation that the incidence matrix  $\mathbf{I}^{(2,1)}(\nu, n)$  (Fig.11) given by

$$\begin{aligned}
(\mathbf{I}^{(2,1)}(\nu, n))_{-2n,k} &= -\delta_{-2n,k} - \delta_{-2n+1,k} + \delta_{-2n+2,k} \\
(\mathbf{I}^{(2,1)}(\nu, n))_{k,-2n} &= -\delta_{-2n,k} + \delta_{-2n+1,k} + \delta_{-2n+2,k} \\
(\mathbf{I}^{(2,1)}(\nu, n))_{-2l,k} &= \delta_{-2l+2,k} - \delta_{-2l+1,k} - \delta_{-2l-1,k} + \delta_{-2l-2,k} \quad \text{for } 1 \leq l \leq n-1 \\
(\mathbf{I}^{(2,1)}(\nu, n))_{k,-2k} &= \delta_{-2l+2,k} + \delta_{-2l+1,k} + \delta_{-2l-1,k} + \delta_{-2l-2,k} \quad \text{for } 1 \leq l \leq n-1 \\
(\mathbf{I}^{(2,1)}(\nu, n))_{-2l+1,k} &= \delta_{-2l+2,k} + \delta_{-2l+1,k} + \delta_{-2l,k} \quad \text{for } 1 \leq l \leq n \\
(\mathbf{I}^{(2,1)}(\nu, n))_{k,-2l+1} &= -\delta_{-2l+2,k} + \delta_{-2l+1,k} - \delta_{-2l,k} \quad \text{for } 1 \leq l \leq n \\
(\mathbf{I}^{(2,1)}(\nu, n))_{0,k} &= -\delta_{1,k} + \delta_{2,k} - \delta_{-1,k} + \delta_{-2,k} \\
(\mathbf{I}^{(2,1)}(\nu, n))_{k,0} &= \delta_{1,k} + \delta_{2,k} + \delta_{-1,k} + \delta_{-2,k}
\end{aligned} \tag{8.1}$$

with  $-2n \leq k \leq \nu$

$$(\mathbf{I}^{(2,1)}(\nu, n))_{j,k} = (\mathbf{I}(2, 4\nu))_{j,k} \quad \text{for } 1 \leq k, j \leq \nu \tag{8.2}$$

and  $\mathbf{C}^{(2,1)}(\nu, n) = 2 - \mathbf{I}^{(2,1)}(\nu, n)$  give the following trinomial identities for the model  $M(2(\nu + n) + 1, 4(\nu + n))$

$$\begin{aligned}
&\sum_{\substack{\mathbf{m} \\ m_\nu \equiv 0 \pmod{2}}} q^{\frac{1}{4}\mathbf{m}\mathbf{C}^{(2,1)}(\nu, n)\mathbf{m}} \prod_{j=-2n}^{\nu} \left[ \begin{matrix} (\frac{1}{2}\mathbf{I}^{(2,1)}(\nu, n)\mathbf{m} + L\mathbf{e}_{-2n})_j \\ m_j \end{matrix} \right]_q \\
&= B_1(L, 2(\nu + n) + 1, 4(\nu + n)).
\end{aligned} \tag{8.3}$$

The bosonic polynomials in these identities depend on only  $\nu + n$  whereas the size of the matrices appearing in the right hand side of these identities is  $\nu + 2n + 1$  so that the fermionic sides look very different while the bosonic sides are identical. Thus for every distinct partition of the number  $\nu + n$  into two parts we obtain different identities. This is a new phenomenon which we refer to as ‘‘families’’ of identities.

8.2. The perturbation  $\phi_{1,5}$  of  $M(2(\nu + n) + 1, 4(\nu + n) + 4)$

Similarly we find for the  $\phi_{(1,5)}$  perturbation that the incidence matrix  $\mathbf{I}^{(1,5)}(\nu, n)$  (Fig. 12) given by

$$(\mathbf{I}^{(1,5)}(\nu, n))_{j,k} = (\mathbf{I}^{(2,1)}(\nu, n + 1))_{j,k} \quad \text{for } -2n - 1 \leq j, k \leq \nu \tag{8.4}$$

gives the polynomial identities for the model  $M(2(\nu + n) + 1, 4(\nu + n) + 4)$

$$\sum_{\substack{\mathbf{m} \\ m_\nu \equiv 0 \pmod{2}}} q^{\frac{1}{4}(L(L-m_{-2n-1})+\mathbf{m}\mathbf{C}^{(1,5)}(\nu,n)\mathbf{m})} \prod_{j=-2n-1}^{\nu} \left[ \begin{array}{c} (\frac{1}{2}\mathbf{I}^{(1,5)}(\nu,n)\mathbf{m} + \frac{L}{2}(\mathbf{e}_{-2n} + \mathbf{e}_{-2n-1}))_j \\ m_j \end{array} \right]_q$$

$$= B_2(L, 2(\nu + n) + 1, 4(\nu + n) + 4)$$
(8.5)

with  $\mathbf{C}^{(1,5)}(\nu, n) = 2 - \mathbf{I}^{(1,5)}(\nu, n)$ .

### 8.3. The family of identities for the $\phi_{2,1}$ perturbation of $M(\bar{p}, \bar{p}')$ for $3/2 < \bar{p}'/\bar{p} < 2$ .

The phenomena of families of fermionic representations of the same bosonic characters is not limited to the models  $M(p, 2p \pm 2)$ . To see this we further generalize the starting identity (7.4). We do this by noting that the identity (6.1) which is valid when in the decomposition (6.6)  $\nu_0 \geq 2$  may be extended to the case  $\nu_0 = 1$  by defining for this case the incidence matrix  $\mathbf{I}^{(2)'}$  ( $p, p'$ ) (Fig. 13) as

$$\begin{aligned} (\mathbf{I}^{(2)'}(p, p'))_{j,i} &= \delta_{j-1,i} + \delta_{j+1,i} \text{ for } j \neq t'_l, \quad 1 \leq l \leq f \\ (\mathbf{I}^{(2)'}(p, p'))_{1,i} &= \delta_{1,i} - \delta_{2,i} \\ (\mathbf{I}^{(2)'}(p, p'))_{t'_l,i} &= \delta_{-1+t'_l,i} + \delta_{t'_l,i} - \delta_{1+t'_l,i} \text{ for } 1 \leq l \leq f-1 \\ (\mathbf{I}^{(2)'}(p, p'))_{t'_f,i} &= \delta_{-1+t'_f,i} + \delta_{\nu_f,0} \delta_{t'_f,i} \end{aligned}$$
(8.6)

with  $1 \leq i, j \leq t'_f$ ,  $t'_l = 1 + \sum_{j=1}^l \nu_j$  and the fermionic form  $F^{(2)'}$  ( $L, p, p'$ ) as

$$F^{(2)'}(L, p, p') = \sum_{\substack{\mathbf{m} \\ m_{t_f} \equiv 0 \pmod{2}}} q^{\frac{1}{4}(L(L-2m_2)+\mathbf{m}\mathbf{C}^{(2)'}(p,p')\mathbf{m})} \prod_{j=1}^{t'_f} \left[ \begin{array}{c} (\frac{1}{2}\mathbf{I}^{(2)'}(p,p')\mathbf{m} + \frac{L}{2}(\mathbf{e}_1 + \mathbf{e}_2))_j \\ m_j \end{array} \right]_q$$
(8.7)

with  $\mathbf{C}^{(2)'}(p, p') = 2 - \mathbf{I}^{(2)'}(p, p')$  to obtain the identity

$$F^{(2)'}(L, p, p') = B^{(2)}(L, p, p')$$
(8.8)

with  $B^{(2)}(L, p, p')$  given by (6.2) and

$$\frac{p'}{p' - p} = 2 + \frac{1}{\nu_1 + \frac{1}{\nu_2 + \dots + \frac{1}{2 + \nu_f}}}$$
(8.9)

Special cases of (8.8) are easily verified on the computer and a general proof will be given elsewhere.

Using this as a starting identity we proceed as before and for  $f \geq 2$  define  $\bar{p}', \bar{p}$  from  $p, p'$  and an integer  $n \geq 0$  as

$$\frac{\bar{p}'}{\bar{p}' - \bar{p}} = 2 + \frac{1}{n + \nu_1 + \frac{1}{\nu_2 + \dots + \frac{1}{\nu_f + 2}}} \quad (8.10)$$

We then obtain the identities

$$\begin{aligned} \sum_{\substack{\mathbf{m} \\ m_{t_f} \equiv 0 \pmod{2}}} q^{\frac{1}{4} \mathbf{m} \mathbf{C}^{(2,1)}(p, p', n) \mathbf{m}} \prod_{j=-2n}^{t_f} \left[ \begin{matrix} (\frac{1}{2} \mathbf{I}^{(2,1)}(p, p', n) \mathbf{m} + L \mathbf{e}_{-2n})_j \\ m_j \end{matrix} \right]_q \\ = B_1(L, \bar{p}, \bar{p}') \end{aligned} \quad (8.11)$$

where  $\mathbf{C}^{(2,1)}(p, p', n) = 2 - \mathbf{J}^{(2,1)}(p, p', n)$  and  $\mathbf{I}^{(2,1)}(p, p', n)$ , given graphically by Fig.14, is

$$\begin{aligned} (\mathbf{I}^{(2,1)}(p, p', n))_{i,j} &= (\mathbf{I}^{(2,1)}(\nu, n))_{i,j} \quad -2n \leq i, j \leq 2 \\ (\mathbf{I}^{(2,1)}(p, p', n))_{j,i} &= (\mathbf{I}^{(2)'}(p, p'))_{j,i} \quad 1 \leq j, i \leq t_f \end{aligned} \quad (8.12)$$

and zero otherwise. Clearly (8.11) reduces to (8.3) when  $f = 2, \nu_2 = 0$  and  $\nu = \nu_1 + 1$ . We also note that the models described by these representations have already been studied in sec. 6 in terms of the incidence matrix  $\mathbf{J}^{(2,1)}(\bar{p}, \bar{p}')$ .

When  $f = 1$  we replace (8.10) by

$$\frac{\bar{p}'}{\bar{p}' - \bar{p}} = 2 + \frac{1}{n + 2 + \nu_1} \quad (8.13)$$

and with this definition the results (8.11) and (8.12) are unchanged. This case is the model  $M(\bar{p}, 2\bar{p} - 1)$  with  $\bar{p} = 3 + n + \nu_1$ .

#### 8.4. The family of identities for the $\phi_{1,5}$ perturbation of $M(\bar{p}, \bar{p}')$ for $2 < \bar{p}'/\bar{p} < 5/2$ .

Similarly for the perturbations  $\phi_{1,5}$  we define for  $f \geq 2$  another pair  $\bar{p}, \bar{p}'$  from the pair  $p, p'$  as given in (8.9) and an integer  $n \geq 0$  as

$$\frac{\bar{p}'}{\bar{p}} = 2 + \frac{1}{n + 1 + \nu_1 + \frac{1}{\nu_2 + \dots + \frac{1}{\nu_f + 2}}} \quad (8.14)$$

and find the family of identities

$$\begin{aligned} \sum_{\substack{\mathbf{m} \\ m_{t_f} \equiv 0 \pmod{2}}} q^{\frac{1}{4} (L(L-2m_{-2n-1}) + \mathbf{m} \mathbf{C}^{(1,5)}(p, p', n) \mathbf{m})} \prod_{j=-2n-1}^{t_f} \left[ \begin{matrix} \frac{1}{2} (\mathbf{I}^{(1,5)}(p, p', n) \mathbf{m} + L(\mathbf{e}_{-2n} + \mathbf{e}_{-2n-1}))_j \\ m_j \end{matrix} \right]_q \\ = B_1(L, \bar{p}, \bar{p}') \end{aligned} \quad (8.15)$$

where  $\mathbf{C}^{(1,5)}(p, p', n) = 2 - \mathbf{I}^{(1,5)}(p, p', n)$  and  $\mathbf{I}^{(1,5)}(p, p', n)$ , given graphically in fig.15 is

$$(\mathbf{I}^{(1,5)}(p, p', n))_{i,j} = (\mathbf{I}^{(2,1)}(p' - p, p', n + 1))_{i,j} \quad -2n - 1 \leq i, j \leq t'_f \quad (8.16)$$

which reduces to (8.5) when  $f = 2, \nu_2 = 0$  and  $\nu = \nu_1 + 1$ .

When  $f = 1$  (8.14) is replaced by

$$\frac{\bar{p}'}{\bar{p}} = 2 + \frac{1}{3 + n + \nu_1} \quad \text{with } n \geq 0, \nu_1 \geq 1 \quad (8.17)$$

and with this definition (8.15) and (8.16) continue to hold. In this case the model is  $M(\bar{p}, 2\bar{p} + 1)$  with  $\bar{p} = 3 + n + \nu_1$ .

## 9. Additional fermionic representations for the models $M(p, 2p \pm 1)$

For the models  $M(2p, 2p \pm 1)$  there is yet one further representation which has not been obtained in sec. 8. This representation is needed in order to make contact with [29]. To derive this additional representation we use an identity proven by Andrews [51] for the first model of the series  $M(2, 5)$

$$\sum_{n=0}^{\infty} q^{n^2} \begin{bmatrix} L - n \\ n \end{bmatrix}_q = B_2(L, 2, 5) \quad (9.1)$$

where  $B_2(L, 2, 5)$  is defined by (5.7). An alternative proof is given in the appendix. We note that the left hand side of (9.1) is the same as that of the polynomial analogue of the Rogers-Ramanujan identities [52]-[54]. The right hand side is however of a very different form than [53] because it involves  $q$ -trinomials instead of  $q$ -binomials.

We can now apply the TABL (2.10) to (9.1) and (letting  $(L, n) \rightarrow (m_1, m_2)$ ) we obtain

$$\sum_{m_1, m_2=0}^{\infty} q^{m_2^2 + m_1^2 - m_1 m_2} \frac{1}{(q)_{m_1}} \begin{bmatrix} m_1 - m_2 \\ m_2 \end{bmatrix}_q = \chi_{1,2}^{(3,5)}. \quad (9.2)$$

This can be generalized to the polynomial identity

$$\sum_{m_1, m_2=0}^{\infty} q^{m_1^2 + m_2^2 - m_1 m_2} \begin{bmatrix} L - m_1 + m_2 \\ m_1 \end{bmatrix}_q \begin{bmatrix} m_1 - m_2 \\ m_2 \end{bmatrix}_q = B_1(L, 3, 5) \quad (9.3)$$

which has been checked to high orders on the computer. The fermionic side of (9.3) is of the canonical form (3.4) where  $\mathbf{B} = \mathbf{C}_2$  is the Cartan matrix for  $A_2$  as defined in (1.6).

This procedure may now be repeated indefinitely as done in the previous sections and we obtain the following trinomial identities:

$$\sum_{\mathbf{m}} q^{\frac{1}{2}\mathbf{m}\mathbf{C}_n\mathbf{m}} \prod_{j=1}^n \left[ \begin{matrix} (1 - \mathbf{C}_n)\mathbf{m} + L\mathbf{e}_1 \\ m_j \end{matrix} \right]_q = \begin{cases} B_1(L, \frac{n+4}{2}, n+3) & \text{for } n \text{ even} \\ B_2(L, \frac{n+3}{2}, n+4) & \text{for } n \text{ odd.} \end{cases} \quad (9.4)$$

where  $\mathbf{C}_n$  is defined in (1.6). The matrix in the quadratic form  $\mathbf{C}_n$  is exactly the same as the TBA matrix  $T_1 \times A_n$  proposed in [29] for the  $\phi_{2,1}$  perturbation of  $M(\frac{n+4}{2}, n+3)$  for  $n$  even and for the  $\phi_{1,5}$  perturbation of  $M(\frac{n+3}{2}, n+4)$  for  $n$  odd. This confirms our previous identification of the polynomial  $B_1(L, p, p')$  with the  $\phi_{2,1}$  perturbation and provides the most direct evidence that  $B_2(L, p, p')$  is to be identified with the  $\phi_{1,5}$  perturbation.

## 10. Discussion

We have now completed our study of the use of the trinomial analogue of Bailey's lemma to give the Rogers-Ramanujan type identities relevant for the  $\phi_{2,1}$  and  $\phi_{1,5}$  perturbations of conformal field theory. However, before we conclude we wish to make several observations about our work.

First, it should be remarked, that we have presented here many conjectured finitizations, which, although amply verified on the computer, remain to be proven. In principle this is can be done by using  $L$  difference equations, telescopic expansions, and the properties of  $q$ -trinomials. This method, however usually involves the use of many of the characters for which we have not yet written down formula and as seen in [39] some of these character formulas are cumbersome once the number  $f$  in the continued fraction expansions like (6.6) becomes large. For that reason it would be useful to extend to  $\phi_{2,1}$  and  $\phi_{1,5}$  perturbations the methods of Burge [55] which have been recently employed [56] to study  $\phi_{1,3}$  representations of some of the  $M(p, p')$  characters. This method has the virtue of allowing the study of the characters with the minimal conformal dimensions  $\chi_{r_m, s_m}^{(p, p')}(q)$  in isolation from the other characters.

More important than the explicit proofs, however, are the implications and interpretations of our results in terms of perturbed conformal field theory and its relation to lattice statistical mechanics. In particular we will here discuss the phenomena of families of identities found in sec. 8.

In sec. 8 we found for the perturbation  $\phi_{2,1}$  of  $M(p, p')$  with  $3p < 2p'$  and for the perturbation  $\phi_{1,5}$  of  $M(p, p')$  with  $2 < p'/p < 5/2$  that we had not just one but a family

of fermionic representation for the same bosonic polynomial. These different fermionic representations should give different TBA systems and the relation of this multiplicity of representations to conformal field theory needs to be elucidated.

It seems to us to be significant that for the  $\phi_{2,1}$  perturbations the fermionic representations found in sec. 4 were unique when  $3p > 2p'$  and that this is exactly the region where perturbative studies [13] have no problems with vacuum identification. The non uniqueness we found in section 8 sets in at exactly the regimes where the study of [13] encountered problems in identification of the vacuum. This is a new phenomena in the study of massive deformations of conformal field theory and needs much further investigation.

One of the most promising ways to make such a study is to extend the study of the dilute  $A_n$  models to fractional levels and to obtain the Bethe Ansatz equations for the systems. In these equations a change of vacuum would be signaled if there were a multiplicity of regions of the spectral variable such that in the different regions different string configurations of the roots which compose the vacuum were allowed.

However this is not the only possibility of interpreting our results. It has been known for many years that in the “repulsive” regime the sine Gordon/massive Thirring model has several different lattice regularizations which lead to different renormalized theories with different properties. One of these regularizations is based on the XYZ model [57]-[60] and the other is based on the R matrix of the XXZ model [61]-[63]. These different regularizations represent different ways to fill the Fermi sea and can lead to different physical results because in the “repulsive” regimes of the sine Gordon theory there is attraction between the particles in the Fermi sea. Such a mechanism also involves a vacuum choice in field theory and could be relevant to the interpretation of our results.

## Appendix A. Proof of 9.1

To prove (9.1) we send  $q \rightarrow 1/q$ , multiply by  $q^{\frac{L^2}{2}}$ , use (2.1), define  $m$  by  $m + n = (m + L)/2$  so that  $L - n = (m + L)/2$ , and use the definition (2.3) with  $n = 0$  to write it as

$$\sum_{m=0}^{\infty} q^{\frac{L^2}{4} + \frac{m^2}{4}} \left[ \begin{matrix} \frac{1}{2}(L+m) \\ m \end{matrix} \right]_q = \sum_{j=-\infty}^{\infty} q^{\frac{5}{2}j^2 + j} [T_0(L, 5j) - T_0(L, 5j + 2)]. \quad (\text{A.1})$$

We call the series on the left hand side  $\phi(L)$  and use the recursion relations for q-binomials

$$\left[ \begin{matrix} L \\ m \end{matrix} \right]_q = \left[ \begin{matrix} L-1 \\ m-1 \end{matrix} \right]_q + q^m \left[ \begin{matrix} L-1 \\ m \end{matrix} \right]_q = q^{L-m} \left[ \begin{matrix} L-1 \\ m-1 \end{matrix} \right]_q + \left[ \begin{matrix} L-1 \\ m \end{matrix} \right]_q \quad (\text{A.2})$$

to show that

$$\phi(L) = q^{L-\frac{1}{2}}\phi(L-1) + q^{L-1}\phi(L-2). \quad (\text{A.3})$$

We will prove that (A.1) holds by proving that the right hand side of (A.1) which we denote as  $B(L)$  satisfies (A.2) and agrees with  $\phi(L)$  for  $L = 0, 1$ .

From the definition of  $B(L)$  we see that

$$\begin{aligned} & B(L) - q^{L-\frac{1}{2}}B(L-1) - q^{L-1}B(L-2) \\ &= \sum_{j=-\infty}^{\infty} q^{\frac{5}{2}j^2+j} [T_0(L, 5j) - q^{L-1/2}T_0(L-1, 5j) - q^{L-1}T_0(L-2, 5j) \\ &\quad - T_0(L, 5j+2) + q^{L-1/2}T_0(L-1, 5j+2) + q^{L-1}T_0(L-2, 5j+2)]. \end{aligned} \quad (\text{A.4})$$

This is simplified first by using (4.1) of [50]

$$\begin{aligned} & T_0(L, A) - q^{L-1/2}T_0(L-1, A) - q^{L-1}T_0(L-2, A) \\ &= T_0(L-1, A+1) + T_0(L-1, A-1) - T_0(L-2, A) \end{aligned} \quad (\text{A.5})$$

to reduce the right hand side of (A.4) to

$$\sum_{j=-\infty}^{\infty} q^{\frac{5}{2}j^2+j} [T_0(L-1, 5j-1) - T_0(L-1, 5j+3) - T_0(L-2, 5j) + T_0(L-2, 5j+2)]. \quad (\text{A.6})$$

The second and fourth terms are combined by use of (4.3) of [50]

$$T_0(L, A) - T_0(L-1, A-1) = q^{A+1/2} [T_0(L, A+1) - T_0(L-1, A+2)] \quad (\text{A.7})$$

with  $A = 5j + 3$  to obtain

$$\begin{aligned} & \sum_{j=-\infty}^{\infty} (q^{\frac{5}{2}j^2+j} [T_0(L-1, 5j-1) - T_0(L-2, 5j)] \\ & \quad - q^{\frac{5}{2}j^2+6j+\frac{7}{2}} [T_0(L-1, 5j+4) - T_0(L-2, 5j+5)]) \end{aligned} \quad (\text{A.8})$$

which is seen to vanish if in the last two terms we let  $j \rightarrow j-1$  and hence  $B(L)$  satisfies the equation for  $\phi(L)$  (A.3). It is easily verified that  $\phi(L) = B(L)$  for  $L = 1, 2$  and thus we have proven (A.1) and (9.1) as desired.

### Acknowledgments

We are pleased to acknowledge useful conversations with G.E. Andrews, V.V. Bazhanov, R.M. Ellem, P. Fendley, V. Korepin, S.O. Warnaar, and A. Schilling. We also wish to thank M. Batchelor, R.J. Baxter and V.V. Bazhanov for hospitality at the Australian National University where this work was started. This work is supported in part by the NSF under DMR9703543 and by the Australian Research Council.

## Figures

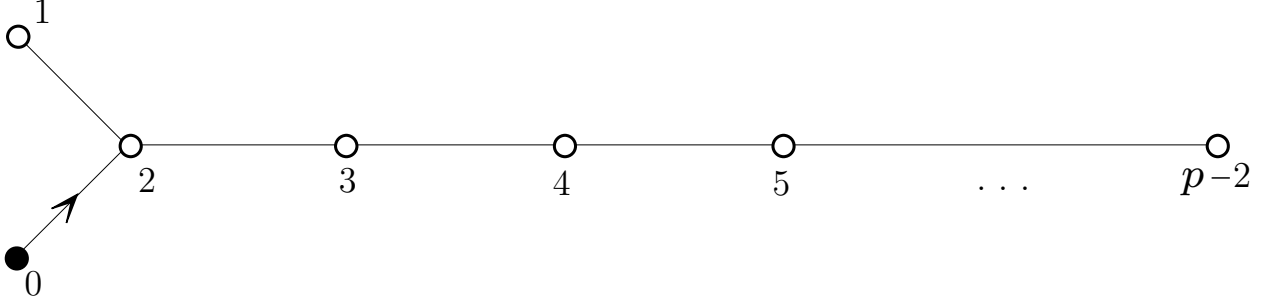

Fig.1 Incidence matrix  $\tilde{\mathbf{I}}_{p-1}$  (3.7) for the  $\phi_{2,1}$  perturbation of  $M(p, p+1)$ . We use the convention that if sites  $a$  and  $b$  are connected by a line then  $(\tilde{\mathbf{I}}_{p-1})_{a,b} = (\tilde{\mathbf{I}}_{p-1})_{b,a} = 1$  and if  $a$  and  $b$  are joined by an arrow pointing from  $a$  to  $b$  then  $(\tilde{\mathbf{I}}_{p-1})_{a,b} = -(\tilde{\mathbf{I}}_{p-1})_{b,a} = -1$ . If a site  $a$  is specified by a filled circle there is an inhomogeneous term  $L\mathbf{e}_a$  in the  $m, n$  system (4.2). These conventions will be used in all the diagrams of this paper.

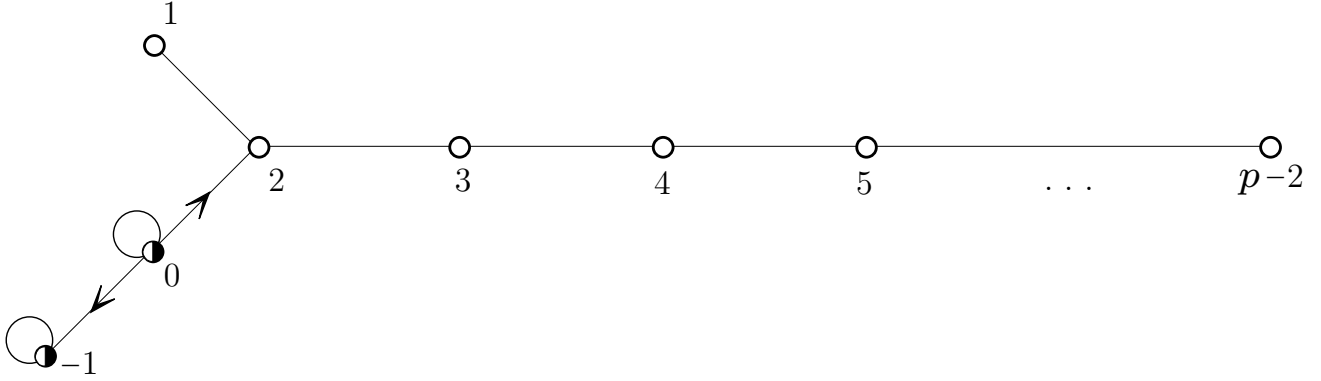

Fig.2 Incidence matrix  $\mathbf{I}'_p$  appearing in (5.5) for the  $\phi_{1,5}$  perturbation of the model  $M(p, 3p-1)$ . The “tadpole” at site  $a$  indicates that  $(\mathbf{I}'_p)_{a,a} = 1$ . The half filled circle at site  $a$  indicates an inhomogeneous term  $\frac{L}{2}\mathbf{e}_a$  in the  $m, n$  system (5.5). These conventions will be used throughout the paper.

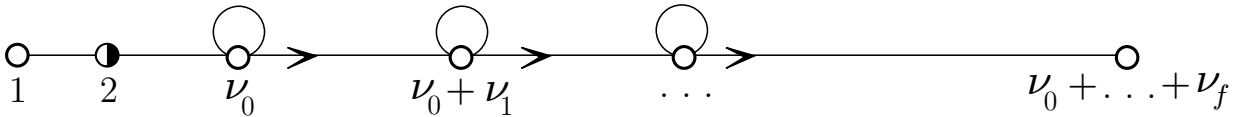

Fig.3 Incidence matrix  $\mathbf{I}^{(2)}(p, p')$  (6.8). The relation between  $p, p'$  and  $\nu_0, \dots, \nu_f$  is given in (6.6). The sites between the tadpole sites are not explicitly shown. The arrow following a tadpole at site  $a$  connects to the site  $a+1$ . The remaining sites are connected by lines (not arrows). This convention is used in all subsequent diagrams.

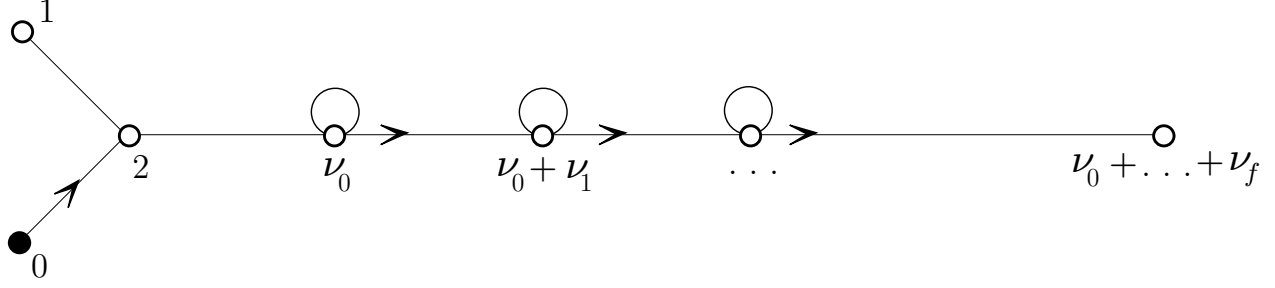

Fig.4 Incidence matrix  $\tilde{\mathbf{I}}^{(2,1)}(p, p')$  (6.11) for the  $\phi_{2,1}$  perturbation of  $M(p, p')$  with  $1 < p'/p < 3/2$ . The relation between  $p, p'$  and  $\nu_0, \dots, \nu_f$  is given in (6.6).

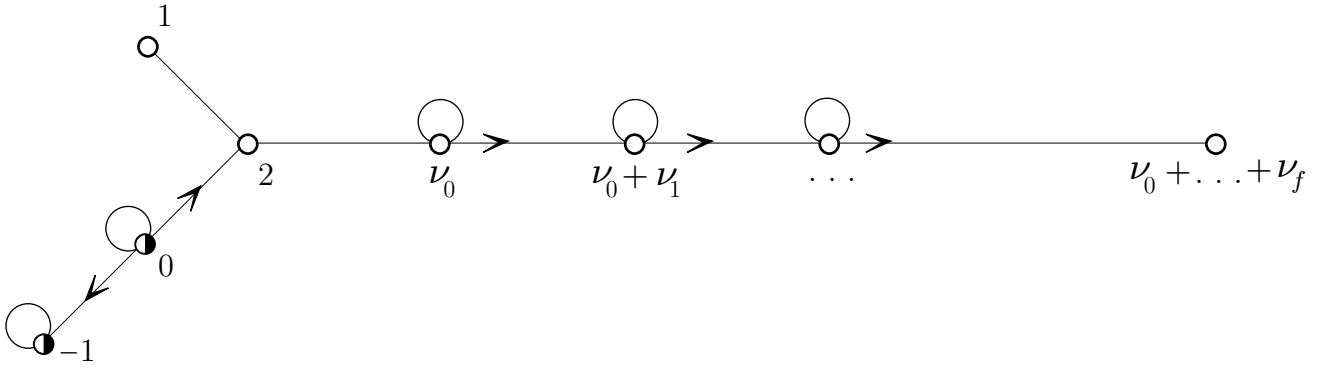

Fig.5 Incidence matrix  $\tilde{\mathbf{I}}^{(1,5)}(p, p')$  (6.14) for the  $\phi_{1,5}$  perturbation of  $M(p, 4p - p')$  with  $1 < p'/p < 3/2$ . The relation between  $p, p'$  and  $\nu_0, \dots, \nu_f$  is given in (6.6).

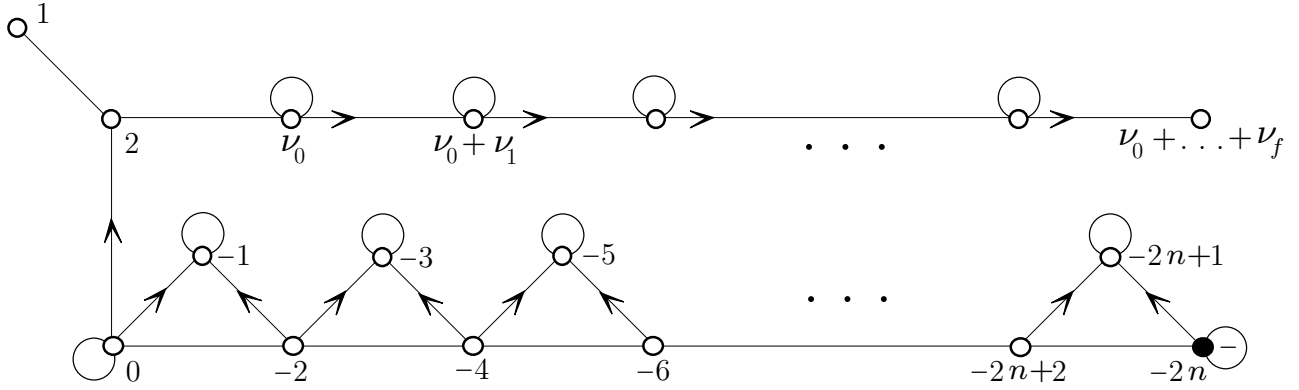

Fig.6 Incidence matrix  $\mathbf{J}^{(2,1)}(\bar{p}, \bar{p}')$  (6.16) for  $\phi_{2,1}$  perturbations of  $M(\bar{p}, \bar{p}')$  with  $3/2 < \bar{p}'/\bar{p} < 2$  and  $\bar{p}' \neq 2\bar{p} - 2$ . The relation between  $\bar{p}, \bar{p}'$  and  $\nu_0, \dots, \nu_f, n$  is given in (6.6), (6.15). The minus sign inside the tadpole at site  $-2n$  indicates that  $(\mathbf{J}^{(2,1)}(\bar{p}, \bar{p}'))_{-2n, -2n} = -1$ . This convention for the “negative tadpole” will be used in all subsequent diagrams.

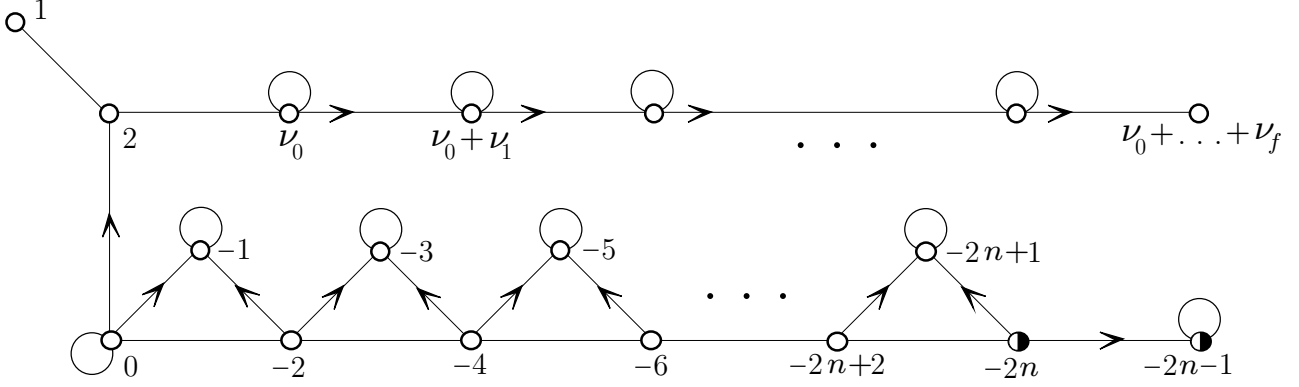

Fig.7 Incidence matrix  $\mathbf{J}^{(1,5)}(\bar{p}, \bar{p}')$  (6.21) for  $\phi_{1,5}$  perturbations of  $M(\bar{p}, \bar{p}')$  with  $2 < \bar{p}'/\bar{p} < 5/2$  and  $\bar{p}' \neq 2\bar{p} + 2$ . The relation between  $\bar{p}, \bar{p}'$  and  $\nu_0, \dots, \nu_f, n$  is given in (6.20).



Fig.8 Incidence matrix  $\mathbf{I}(2, 4\nu)$  (7.2) for the characters of the  $N = 1$  supersymmetric model  $SM(2, 4\nu)$ .

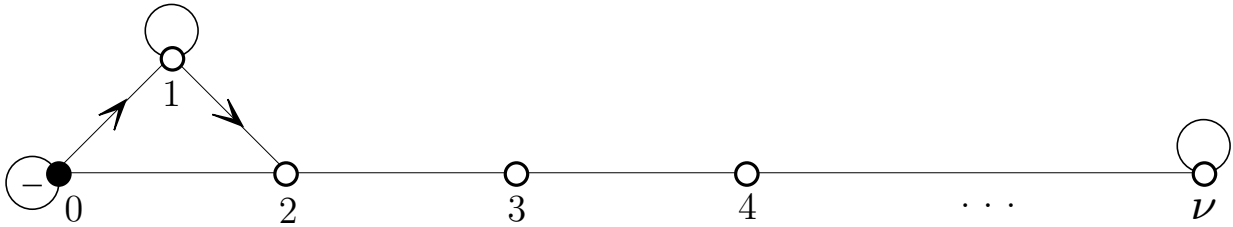

Fig.9 Incidence matrix  $\mathbf{I}^{(2,1)}(\nu)$  (7.7) for the  $\phi_{2,1}$  perturbation of  $M(2\nu + 1, 4\nu)$

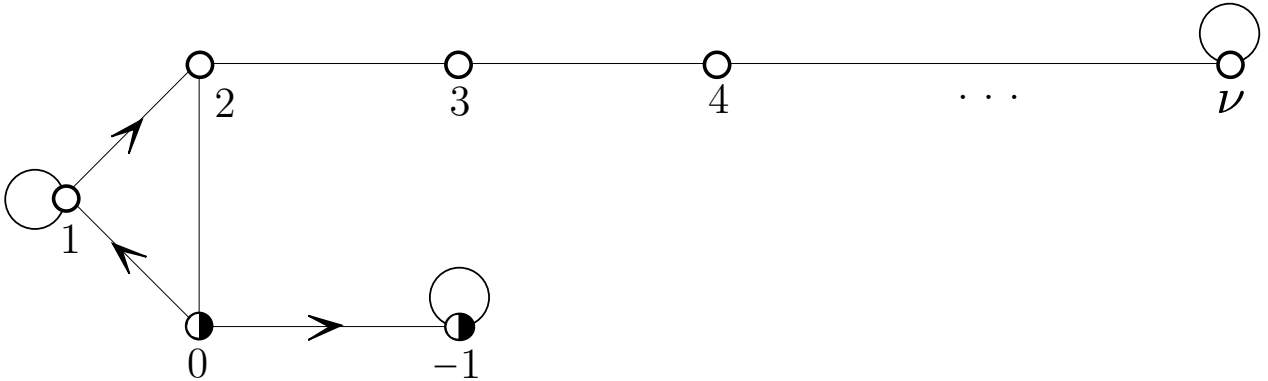

Fig.10 Incidence matrix  $\mathbf{I}^{(1,5)}(\nu)$  (7.10) for the  $\phi_{1,5}$  perturbation of  $M(2\nu + 1, 4\nu + 4)$

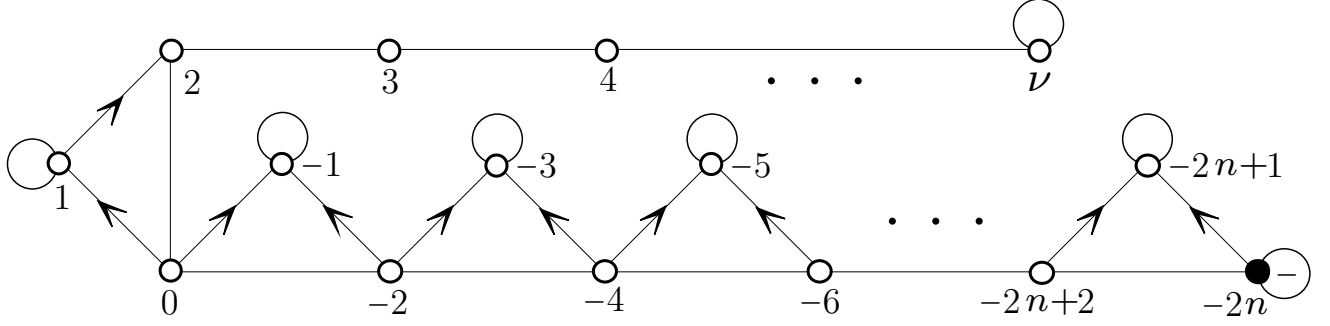

Fig.11 Incidence matrix  $\mathbf{I}^{(2,1)}(\nu, n)$  (8.1) for the families of identities for  $\phi_{2,1}$  perturbations of  $M(2(\nu + n) + 1, 4(\nu + n))$ .

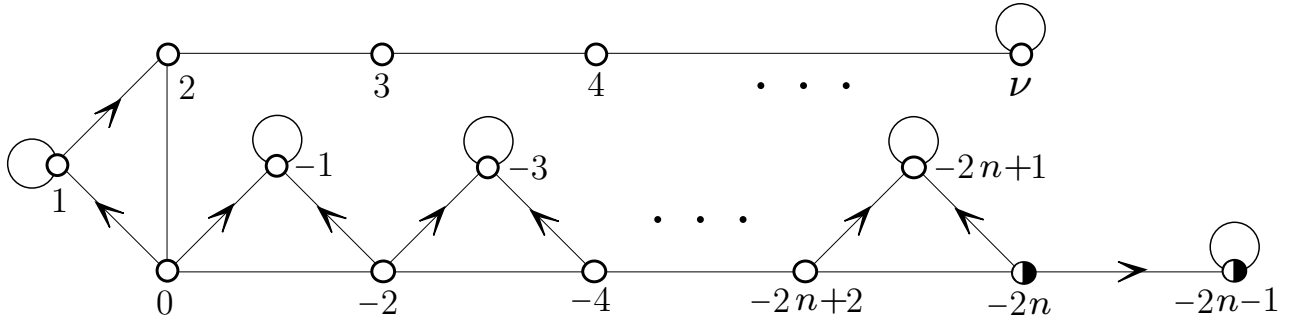

Fig.12 Incidence matrix  $\mathbf{I}^{(1,5)}(\nu, n)$  (8.4) for the family of identities for  $\phi_{1,5}$  perturbations of  $M(2(\nu + n) + 1, 4(\nu + n) + 4)$ .

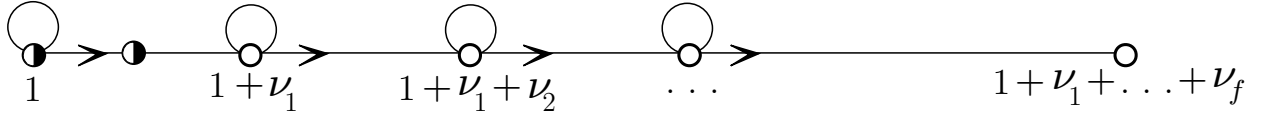

Fig.13 Incidence matrix  $\mathbf{I}^{(2)'}(p, p')$  (8.6) . Note that for  $f = 1$  the only tadpole is at site 1. The relation between  $p, p'$  and  $\nu_1, \dots, \nu_f$  is given in (8.9).

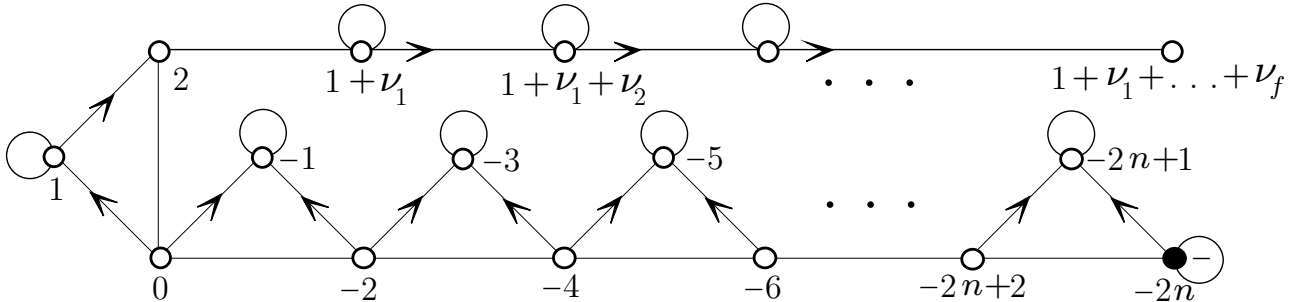

Fig.14 Incidence matrix  $\mathbf{I}^{(2,1)}(p, p', n)$  (8.12) for the  $\phi_{2,1}$  perturbation family of  $M(\bar{p}, \bar{p}')$  for  $3/2 < \bar{p}'/\bar{p} < 2$ . The relation between  $\bar{p}, \bar{p}'$  and  $p, p', n$  is given in (8.9), (8.10). If  $f = 2$  and  $\nu_2 = 0$  this diagram reduces to Fig. 11.

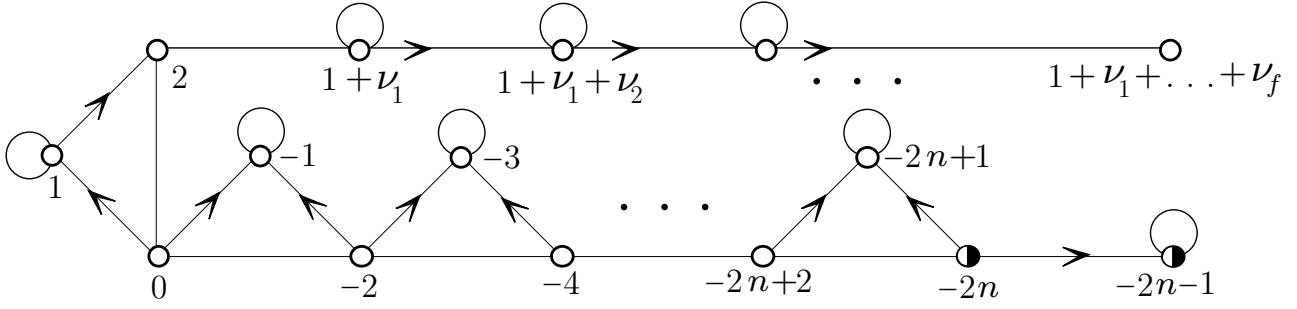

Fig.15 Incidence matrix  $\mathbf{I}^{(1,5)}(p, p', n)$  (8.16) for the  $\phi_{1,5}$  perturbation family of  $M(\bar{p}, \bar{p}')$  for  $2 < \bar{p}'/\bar{p} < 5/2$ . The relation between  $\bar{p}, \bar{p}'$  and  $p, p', n$  is given in (8.9) and (8.14).

## References

- [1] A.B. Zamolodchikov, Higher-order integrals of motion in two-dimensional models of field theory with a broken conformal symmetry, *JETP Lett.* 46 (1987) 160.
- [2] A.B. Zamolodchikov, Integrals of motion in scaling 3-state Potts model field theory, *Int. J. Mod. Phys. A3* (1988) 743.
- [3] A.B. Zamolodchikov, Integrable field theory from conformal field theory, *Advanced Studies in Pure Math.* 19 (1989),641.
- [4] G.E. Andrews, R.J. Baxter and P.J. Forrester, Eight-vertex SOS model and generalized Rogers-Ramanujan-type identities, *J. Stat. Phys.* 35 (1984) 193.
- [5] P.J. Forrester and R.J. Baxter, Further exact solution of the eight-vertex SOS model and generalizations of the Rogers-Ramanujan identities, *J. Stat. Phys.* 38 (1985) 435.
- [6] C.N. Yang and C.P. Yang, One-dimensional chain of anisotropic spin-spin interactions. I Proof of Bethe's hypothesis for ground state in a finite system, *Phys. Rev.* 150 (1966) 321; One-dimensional chain of anisotropic spin-spin interactions. II. Properties of the ground-state energy per lattice site for an infinite system, *Phys. Rev.* 150 (1966) 327
- [7] R.J. Baxter, Eight -vertex model in lattice statistics, *Phys. Rev. Lett.* 26 (1971) 832; One-dimensional anisotropic Heisenberg model, *Phys. Rev. Lett.* 26 (1971) 834.
- [8] M.Takahashi and M. Suzuki, One dimensional anisotropic Heisenberg model at finite temperatures, *Prog. Theo. Phys.* 48 (1992) 2187.
- [9] A. Leclair, Restricted Sine Gordon theory and the minimal conformal series, *Phys. Lett. B* 230 (1989) 103.
- [10] F.A. Smirnov, Reductions of quantum sine-Gordon model as perturbations of minimal models of conformal field theory, *Nucl. Phys. B*337 (1990) 156.
- [11] Al.B. Zamolodchikov, Thermodynamic Bethe Ansatz for RSOS scattering theories, *Nucl. Phys. B*358 (1991) 497; ;From tricritical Ising to critical Ising by thermodynamic Bethe Ansatz, *Nucl. Phys. B*358 (1991)524.
- [12] S. Lukyanov and A.B. Zamolodchikov, Exact expectation values of local fields in the quantum sine Gordon model, *Nucl. Phys. B* 493 (1997) 571.
- [13] V. Fateev, S. Lukyanov, A.B. Zamolodchikov and Al. B Zamolodchikov, Expectation values of local fields in Bullough-Dodd model and integrable perturbed conformal field theories, [hep-th 9709034](#)
- [14] A.G.Izergin and V. Korepin, The inverse scattering method approach to the quantum Shabat-Mikhailov model, *Comm. Math. Phys.* 79 (1981) 303
- [15] R.K. Dodd and R.K. Bullough, Polynomial conserved identities for the sine-Gordon equations, *Proc. Roy. Soc. Lond.* A352 (1977) 481.
- [16] A.V. Zhiber and A.B. Shabat, Klein-Gordon equations with a nontrivial group, *Sov.*

- Phys. Dokl. 24 (1979) 607; A.V. Mikhailov, Pis'ma Zh. Eksp. Theor.Fiz. 30 (1979) 443.
- [17] S.O. Warnaar, B. Nienhuis and K. Seton, New construction of solvable lattice models including an Ising model in a field, Phys. Rev. Lett. 69 (1992) 710; A critical ising model in a magnetic field, Int. J. Mod. Phys. B7 (1993) 3727.
- [18] Ph. Roche, On the construction of integrable dilute ADE models, Phys. Lett. B285 (1992) 49
- [19] S.O. Warnaar, P.A. Pearce, K.A. Seaton, and B. Nienhuis, Order parameters of the dilute A models, J. Stat. Phys. 74 (1994) 469.
- [20] A. Kuniba, Exact solution of solid-on-solid models for twisted affine Lie algebras  $A_{2n}^{(2)}$  and  $A_{2n-1}^{(2)}$ , Nucl. Phys. B355 (1991) 801
- [21] F.A. Smirnov, Exact S-matrices for  $\phi_{1,2}$  perturbed minimal models of conformal field theory, Int. J. Mod. Phys. A6 (1991) 1407.
- [22] F. Colomo, A. Koubek and G. Mussardo, The subleading magnetic deformation of the tricritical Ising model in two dimensions as RSOS restrictions of the Izergin-Korepin model, Phys. Lett. B274 (1992) 367; On the S matrix of the subleading magnetic deformation of the tricritical Ising model in two dimensions, Int. J. Mod. Phys. A7 (1992) 5281.
- [23] A. Koubek, M.J. Martins and G. Mussardo, Scattering matrices for  $\phi_{1,2}$  perturbed conformal models in absence of kink states, Nucl. Phys. B 368 (1992) 591.
- [24] A. Koubek, S matrices of  $\phi_{1,2}$  perturbed minimal models; IRF formulation and bootstrap program, Int. J. Mod. Phys. A9 (1994) 1909
- [25] R.M. Ellem and V.V. Bazhanov, Thermodynamic Bethe Ansatz for the subleading magnetic perturbation of the tricritical Ising model, hep-th 9703026
- [26] Al. B. Zamolodchikov, Thermodynamic Bethe Ansatz in relativistic models: scaling 3-state Potts and Lee-Yang models, Nucl. Phys. B342 (1990) 695
- [27] M.J. Martins, Exact resonance ADE S-matrices and their renormalization group trajectories, Nucl. Phys. B394 (1993) 339.
- [28] D. Fioravanti, F. Ravanini and M. Stanishkov, Generalized KdV and quantum inverse scattering description of conformal minimal models, Phys. Lett. B367 (1996) 113.
- [29] F. Ravanini, M. Stanishkov and R. Tateo, Integrable perturbation of CFT with complex parameter: the  $M(3,5)$  model and its generalizations, Int. J. Mod. Phys. A11 (1996) 677.
- [30] G. Takacs, A New RSOS restriction of the Zhiber-Mikhailov-Shabat model and  $\phi_{1,5}$  perturbations of nonunitary minimal models, Nucl. Phys. B489 (1997) 532; H. Kausch, G. Takacs and G. Watts, On the relation of  $\phi_{1,2}$  and  $\phi_{1,5}$  perturbed models and unitarity, Nucl. Phys. B489 (1997) 557.
- [31] V.V. Bazhanov, B. Nienhuis and S.O. Warnaar, Lattice Ising model in a field:  $E_8$

- scattering theory, Phys. Lett. B 322 (1994) 198.
- [32] G. Albertini, B.M. McCoy and J.H.H. Perk, Eigenvalue spectrum of the superintegrable chiral Potts model, Adv. Studies in Pure Math. vol. 19 eds. M. Jimbo, T. Miwa and A. Tsuchiya, (Kinokuniya-Academic Press, Tokyo 1989).; Phys. Lett. A 135 (1989) 741.
  - [33] R. Kedem, T.R. Klassen, B.M. McCoy and E. Melzer, Fermionic quasi-particle representations for characters of  $(G^{(1)})_1 \times (G^{(1)})_1 / (G^{(1)})_2$ , Phys. Letts. B 304 (1993) 263.
  - [34] R. Kedem, T.R. Klassen, B.M. McCoy and E. Melzer, Fermionic sum representations for conformal field theory characters, Phys. Letts. B 307 (1993) 68.
  - [35] A. Rocha-Caridi, in *Vertex operators in mathematics and physics*, J. Lepowsky et al eds. (Springer, Berlin 1985) p.451.
  - [36] A. Berkovich, Fermionic counting of RSOS states and Virasoro character formulas for the unitary minimal series  $M(\nu, \nu + 1)$ , Nucl. Phys. B 431 (1994) 315.
  - [37] S.O. Warnaar, Fermionic solution of the Andrews-Baxter-Forrester model I. Unification of the TBA and CTM methods, J. Stat. Phys. 82 (1996) 657.
  - [38] A. Berkovich and B.M. McCoy, Continued fractions and fermionic representations for characters of  $M(p, p')$  minimal models, Lett. Math. Phys. 37 (1996) 49.
  - [39] A. Berkovich, B.M. McCoy and A. Schilling, Rogers-Schur-Ramanujan type identities for the  $M(p, p')$  minimal models of conformal field theory, Comm. Math. Phys. (in press), q-alg-9607020.
  - [40] G. Andrews and A. Berkovich, A trinomial analogue of Bailey's lemma and  $N = 2$  superconformal invariance, Comm. Math. Phys. (in press), q-alg 9702008.
  - [41] G. Andrews and A. Berkovich. (in preparation)
  - [42] S.O. Warnaar, Fermionic solution of the Andrews-Baxter-Forrester model II: Proof of Melzer's polynomial identities, J. Stat. Phys. 84 (1996) 49
  - [43] S.O. Warnaar, A note on the trinomial analogue of Bailey's lemma, q-alg 9702021.
  - [44] W.N. Bailey, Some identities in combinatorial analysis Proc. London Math. Soc. (2) 49 (1947) 421; Identities of the Rogers-Ramanujan type, Proc. London Math. Soc. (2) 50 (1949) 1.
  - [45] G.E. Andrews and R.J. Baxter, Lattice gas generalizations of the hard-hexagon model III.  $q$ -trinomial coefficients, J. Stat. Phys. 47 (1987) 297.
  - [46] A. Schilling, Polynomial fermionic forms for the branching functions of the rational coset conformal field theories  $(\widehat{su}(2))_M \times (\widehat{su}(2))_N / (\widehat{su}(2))_{M+N}$ , Nucl. Phys. B 459 (1996) 393.
  - [47] A. Schilling, Multinomial and polynomial bosonic forms for the branching functions of the  $(\widehat{su}(2))_M \times (\widehat{su}(2))_N / (\widehat{su}(2))_{M+N}$  conformal coset models, Nucl. Phys. B 467 (1996) 247.
  - [48] V.A. Fateev, The exact relations between the coupling constants and the masses of

- particles for the integrable perturbed conformal field theories, *Phys. Letts. B* 324 (1994) 45.
- [49] A. Schilling and S.O. Warnaar, Supernomial coefficients, polynomial identities and  $q$ -series, *q-alg* 9701007.
- [50] A. Berkovich, B.M. McCoy and W.P. Orrick, Polynomial identities, indices, and duality for the  $N = 1$  supersymmetric models  $SM(2, 4\nu)$ , *J. Stat. Phys.* 83 (1996) 795.
- [51] G.E. Andrews,  $q$ -Trinomial coefficients and Rogers-Ramanujan type identities, in *Analytic Number Theory*, B. Berndt et al eds. (Boston, Birkhäuser (1990)) 1.
- [52] P.A. MacMahon, *Combinatory Analysis*, vol. 2 (Cambridge University Press, Cambridge 1916)
- [53] I.J. Schur, Ein Beitrag zur additiven Zahlentheorie und zur Theorie der Kettenbrüche, *S-B. Preuss, Akad. Wiss. Phys.-Math. Kl.* (1917) 302.
- [54] G.E. Andrews, A polynomial identity which implies the Rogers-Ramanujan identities, *Scripta Mathematica.* 28 (1970) 297.
- [55] W.H. Burge, Restricted partition identities, *J. Comb. Theor.*, A63 (1993) 210.
- [56] O. Foda, K.S. Lee and T.A. Welsch, A Burge tree of Virasoro-type polynomial identities, *q-alg* 9710025.
- [57] J.D. Johnson, S. Krinsky and B.M. McCoy, Vertical-arrow correlation length in the eight-vertex model and the low-lying excitations of the X-Y-Z Hamiltonian, *Phys. Rev. A*8 (1973) 2526.
- [58] A. Luther, Eigenvalue spectrum of interacting massive fermions in one dimension, *Phys. Rev. B*14 (1976) 2153.
- [59] M. Lüscher, Dynamical charges in the quantized renormalized massive Thirring model, *Nucl. Phys. B*117 (1976) 475.
- [60] G.I. Japaridze, A.A. Nersesyan, and P.B. Wiegmann, Exact results in the two-dimensional  $U(1)$  symmetric Thirring model, *Nucl. Phys. B*230[FS10] (1984) 511.
- [61] V.E. Korepin, The mass spectrum and the S matrix of the massive Thirring model in the repulsive case, *Comm. Math. Phys.* 76 (1980) 165.
- [62] A.G. Izergin and V. Korepin, The lattice quantum sine-Gordon equation, *Lett. Math. Phys.* 5 (1981) 199.
- [63] N.M. Bogolyubov and V.E. Korepin, Structure of the vacuum in the quantum sine-Gordon model, *Phys. Lett. B* 159 (1985) 345.